

1999-2000 ENGINES

1.8L 4-Cylinder

ENGINE IDENTIFICATION

NOTE: For repair procedures not covered in this article, see **ENGINE OVERHAUL PROCEDURES** article in **GENERAL INFORMATION**.

Engines can be identified by an engine identification code, stamped on flange on left rear of cylinder block, as viewed from flywheel. See **ENGINE IDENTIFICATION CODE** table.

ENGINE IDENTIFICATION CODE

Application	Code
Miata (1.8L DOHC)	BP
Protege (1.8L DOHC)	FP

ADJUSTMENTS

VALVE CLEARANCE INSPECTION

1. Ensure engine is cold. Remove valve cover. See **VALVE COVER** under **REMOVAL & INSTALLATION**. Rotate crankshaft clockwise until No. 1 piston is at TDC of compression stroke. Measure valve clearance on cylinders designated "A". See **Fig. 1**.
2. Rotate crankshaft clockwise 360 degrees until cylinder No. 4 is at TDC of compression stroke. Measure valve clearance on cylinders designated "B". See **Fig. 1**.
3. If valve clearance is not within specification, replace tappet adjustment shims. See **VALVE CLEARANCE ADJUSTMENT**. Install valve cover using NEW gasket.

VALVE CLEARANCE ADJUSTMENT

1. Remove valve cover. See **VALVE COVER** under **REMOVAL & INSTALLATION**. Rotate crankshaft clockwise to position camshaft lobes off of tappets on cylinder to be adjusted.
2. Remove camshaft bearing cap bolts, one bearing cap at a time. Install Tappet Holder Clamp (49-T012-003) and Tappet Holder Shaft (49-T012-002), using bearing cap bolt holes. See **Fig. 2**. Repeat for each bearing cap.
3. Align marks on tappet holder shaft and shaft clamp. Tighten bolt "A" to secure tappet holder shaft. See **Fig. 3**. Rotate tappet to be adjusted so that a small screwdriver can be inserted into the notch. Mount Tappet Holder Body (49-T012-001A) onto tappet holder shaft by notch in tappet. Tighten bolt "C" to press down tappet just enough to remove shim. Using a small screwdriver and magnet, remove tappet shim. See **Fig. 2**.

CAUTION: Cylinder head can be damaged if tappet is pressed down too much.

4. Select proper adjustment shim by adding thickness of removed shim, plus measured valve clearance, less the standard valve clearance. See **VALVE CLEARANCE SPECIFICATIONS** table. Insert NEW adjusting shim into valve tappet.
5. Loosen bolts "B" and "C", and remove tappet holder body. Repeat for each tappet to be adjusted. See **Fig. 4**.
6. Remove tappet holder assembly, and tighten camshaft bearing cap bolts to specification, one bearing cap at a time. See **TORQUE SPECIFICATIONS**. Install valve cover using NEW gasket. See **VALVE COVER** under REMOVAL & INSTALLATION.

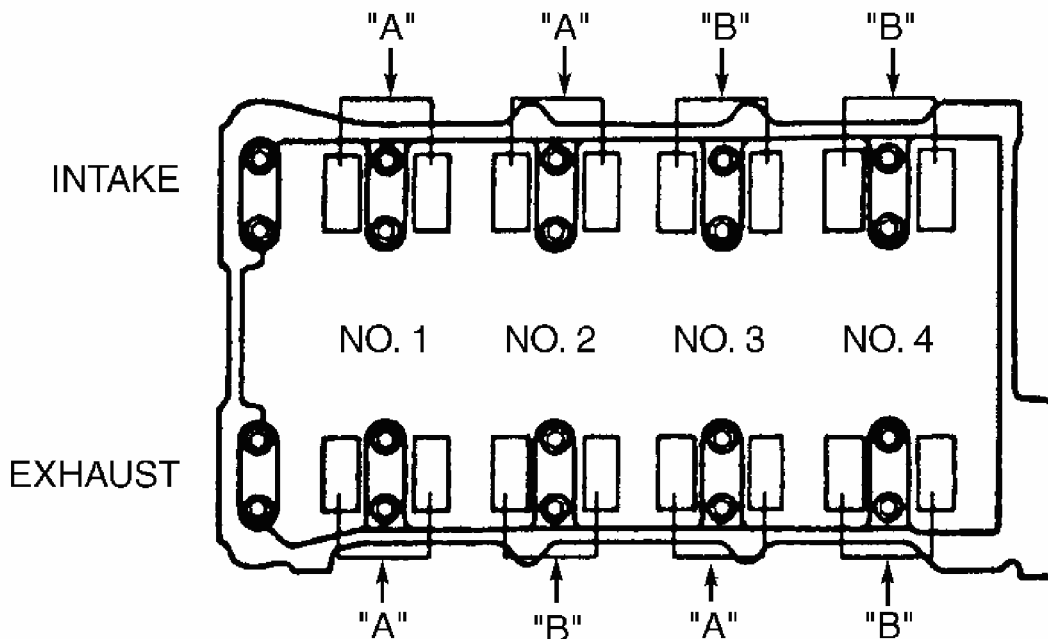

G00008390

Fig. 1: Valve Clearance Inspection Sequence
 Courtesy of MAZDA MOTOR CORP.

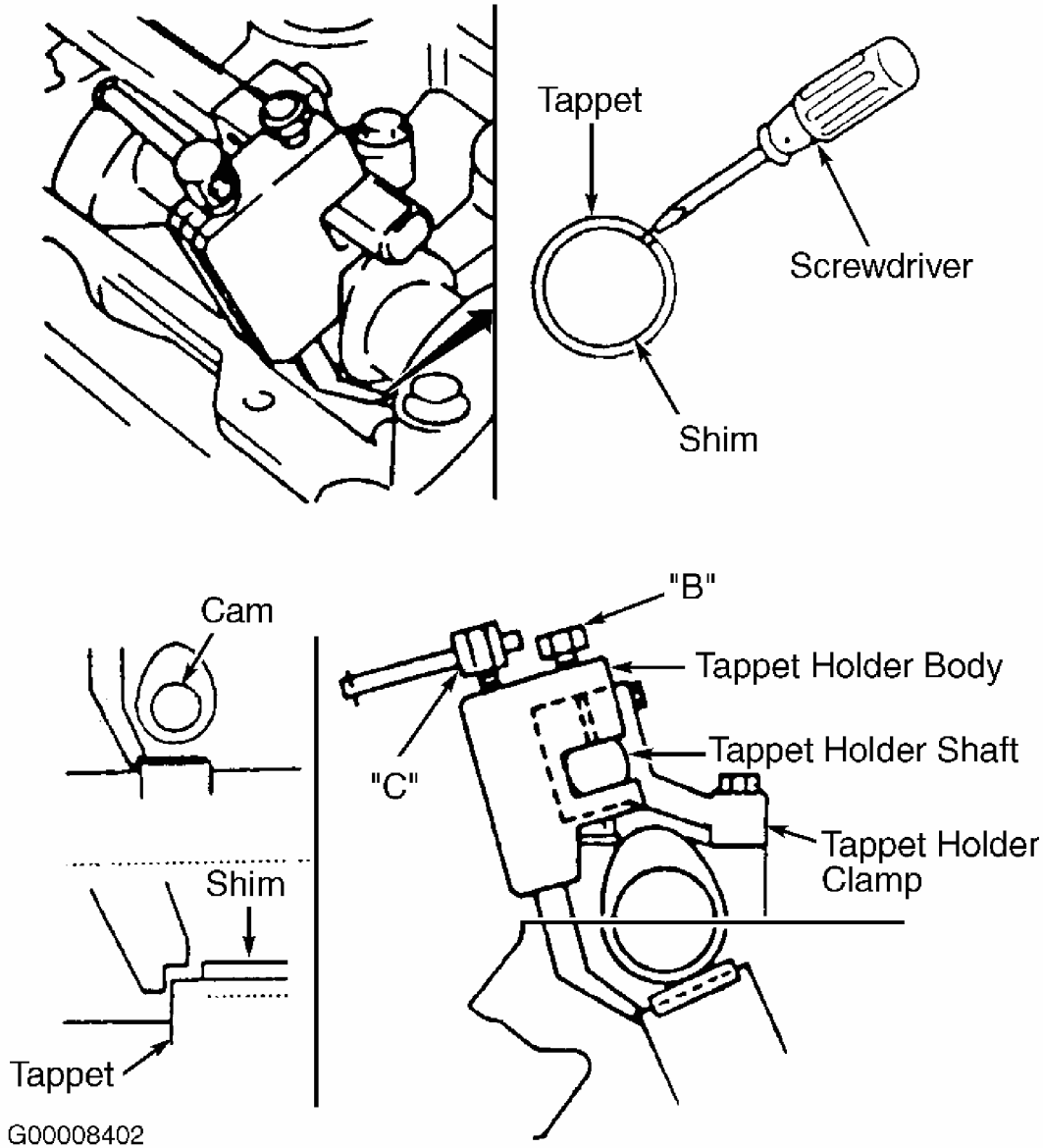
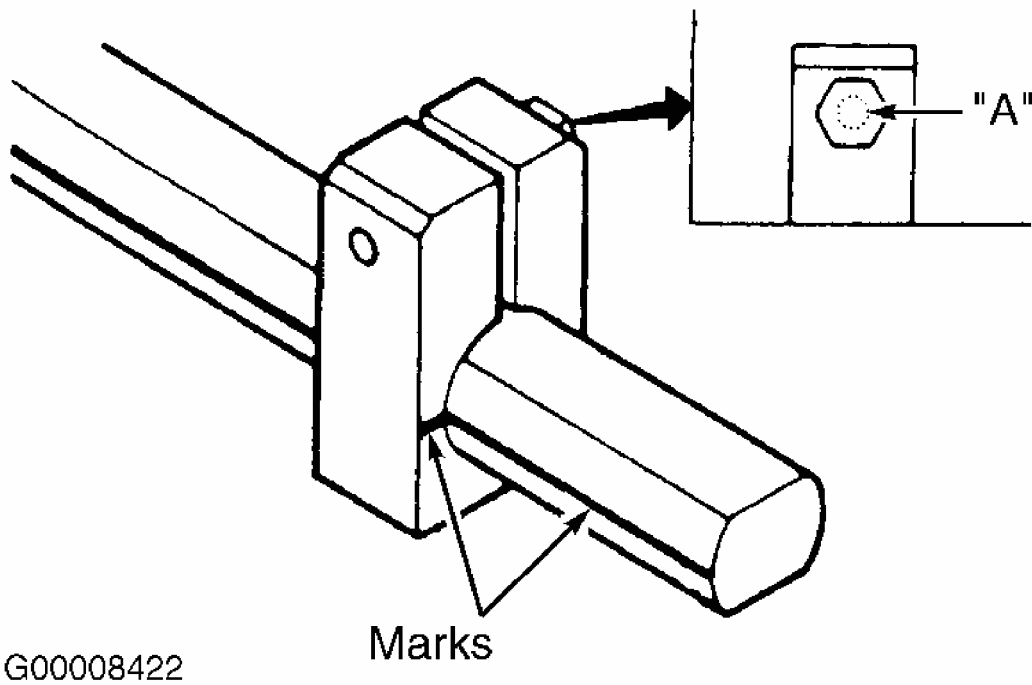

Fig. 2: Identifying Valve Tappet Holder & Adjustment Procedure
Courtesy of MAZDA MOTOR CORP.

1999 Mazda MX-5 Miata

1999-2000 ENGINES 1.8L 4-Cylinder



G00008422

Fig. 3: Aligning Valve Tappet Holder
Courtesy of MAZDA MOTOR CORP.

1999 Mazda MX-5 Miata

1999-2000 ENGINES 1.8L 4-Cylinder

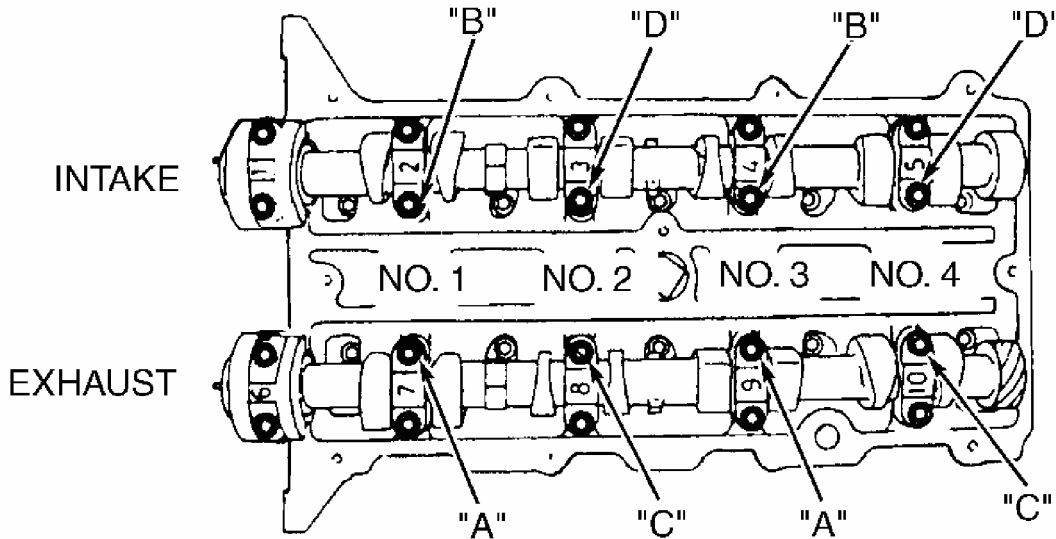

"A" : For exhaust side No. 1, 2, 3 cylinder adjustment shim removal.

"B" : For intake side No. 1, 2, 3 cylinder adjustment shim removal.

"C" : For exhaust side No. 2, 3, 4 cylinder adjustment shim removal.

"D" : For intake side No. 2, 3, 4 cylinder adjustment shim removal.

G00008409

Fig. 4: Valve Adjustment Sequence
Courtesy of MAZDA MOTOR CORP.

VALVE CLEARANCE SPECIFICATIONS

Application	In. (mm)
Miata	
Exhaust	.011-.013 (.28-.34)
Intake	.007-.009 (.18-.23)
Protege	
Exhaust	.009-.012 (.23-.30)
Intake	.009-.012 (.23-.30)

TROUBLE SHOOTING

To trouble shoot engine mechanical components, see appropriate table in TROUBLE SHOOTING article in GENERAL INFORMATION.

REMOVAL & INSTALLATION

CAUTION: When battery is disconnected, vehicle computer and memory systems may lose memory data. Driveability problems may exist until computer systems have completed a relearn cycle.

NOTE: For reassembly reference, label all electrical connectors, vacuum hoses and fuel lines before removal. Also place mating marks on engine hood and other major assemblies before removal.

NOTE: On Miata, with audio-anti-theft system, radio will not operate after reconnecting battery cable, until it has been reactivated. Obtain code from customer to reactivate radio.

FUEL PRESSURE RELEASE & PRIMING

Releasing Pressure

Remove fuel tank filler cap. On Miata, disconnect fuel pump relay, located above accelerator pedal. On Protege, remove fuel pump relay, located in main relay box in engine compartment. On all models, start engine, and allow to run until it stalls. After engine stalls, attempt to restart engine to ensure no residual pressure exists. Turn ignition switch off, and reconnect fuel pump relay. When disconnecting fuel hoses, cover connection with shop rag to catch fuel leakage. To avoid excessive cranking after servicing, prime fuel system before starting engine.

Priming System

Ensure fuel system is closed. Connect jumper wire between F/P and GND terminals of data link connector, or between F/P terminal and body ground. See **Fig. 5**. Turn ignition switch on for about 10 seconds, and check for fuel leaks. Turn ignition off and disconnect jumper wire.

1999 Mazda MX-5 Miata

1999-2000 ENGINES 1.8L 4-Cylinder

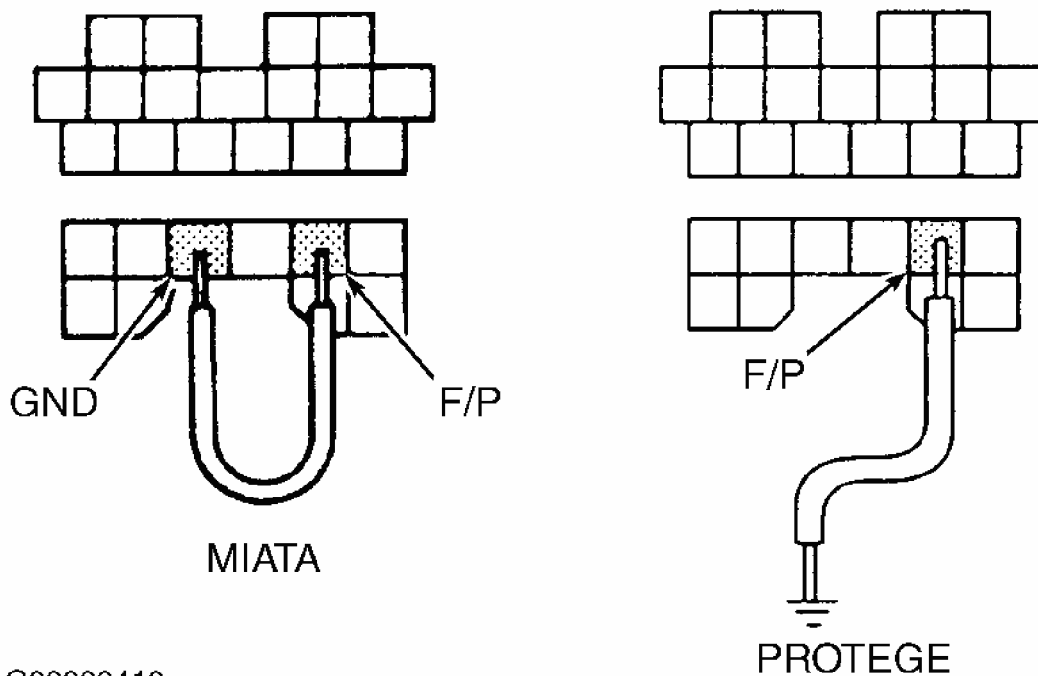

G00008413

Fig. 5: Identifying Data Link Connector Terminals
Courtesy of MAZDA MOTORS CORP.

COOLING SYSTEM BLEEDING

CAUTION: If engine overheats during procedure, system contains excessive air. Stop engine and allow to cool, then repeat step 1.

1. Slowly pour coolant into radiator, at a rate of 1.1 qt. (1.0L) per minute maximum, until coolant is level with filler port. Fill coolant reservoir to "F" mark. Securely install radiator cap. Start engine.
2. Operate engine at idle until normal operating temperature is reached. If coolant level warning light illuminates during warm-up, turn engine off and check for leaks. Operate engine at 2200-2800 RPM for 5 minutes. Stop engine and allow to cool.
3. Repeat steps 1 and 2. Check coolant level. If engine coolant is not level with filler neck, repeat entire procedure. If engine coolant is level with filler neck, fill reservoir to "F" mark. Securely install radiator cap and reservoir cap.

ENGINE

Removal (Miata)

1999 Mazda MX-5 Miata

1999-2000 ENGINES 1.8L 4-Cylinder

1. Release fuel pressure. See **FUEL PRESSURE RELEASE & PRIMING**. Disconnect negative battery cable from trunk-mounted battery. Mark and remove hood. Drain engine, transmission and cooling system fluids. Remove air cleaner assembly and intake air duct.
2. Remove radiator hoses. Disconnect transmission cooler lines (A/T models). Remove cooling fans and radiator. Disconnect throttle cable, and remove bracket. Disconnect all vacuum hoses, heater hoses, fuel lines and engine harness connectors.
3. Remove drive belts. Remove power steering pump with hoses attached, and suspend aside. Remove A/C compressor with hoses attached, and suspend aside.
4. Remove Power Plant Frame (PPF), and remove transmission. For automatic transmission removal procedure, see TRANSMISSION REMOVAL & INSTALLATION article in TRANSMISSION SERVICING. For manual transmission removal procedure, see appropriate article in CLUTCHES.
5. Remove exhaust bracket and disconnect exhaust pipe flange from Warm-Up/Three Way Converter (WU/TWC). See **Fig. 6**. Remove engine mount nuts and engine.

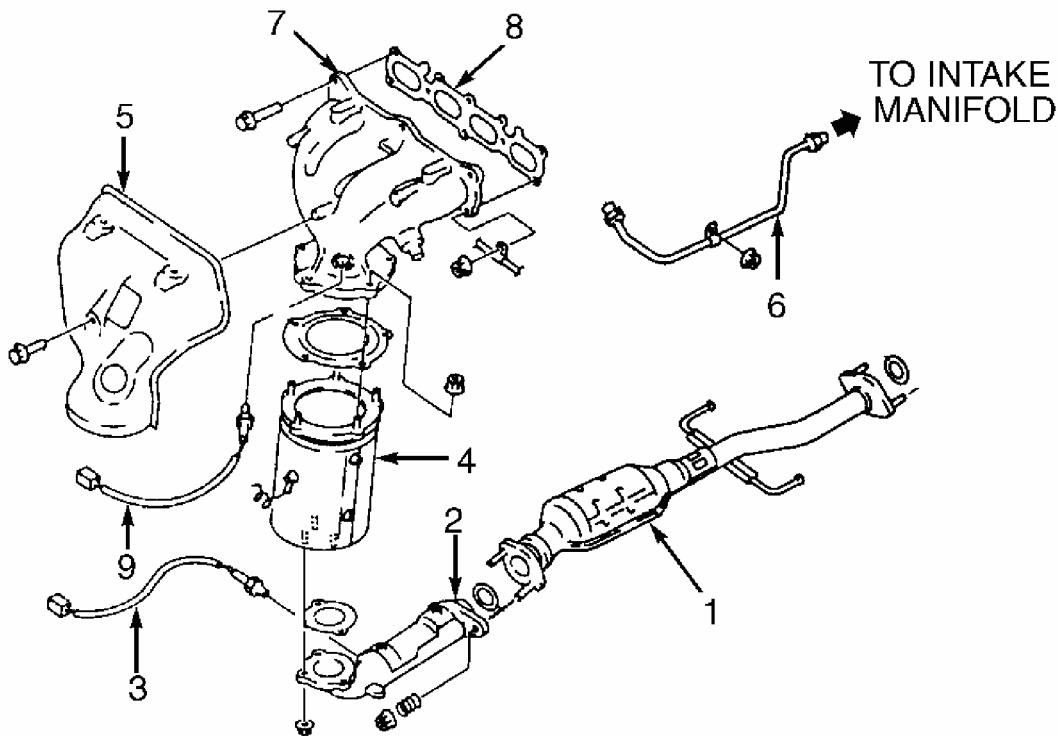

1. TWC (3-Way Converter)
2. Exhaust Pipe
3. HO2 Sensor (Rear)
4. WU/TWC (Warm-Up/3-Way Converter)
5. Heat Shield
6. EGR Pipe
7. Exhaust Manifold
8. Exhaust Manifold Gasket
9. HO2 Sensor (Front)

G00008414

Fig. 6: Exploded View Of Exhaust System (Miata)
 Courtesy of MAZDA MOTORS CORP.

Installation

NOTE: Proper installation of PPF is critical for aligning drive shaft and eliminating harmonic vibrations.

1. To install, reverse removal procedure. Install engine and transmission. To install PPF, ensure transmission is level, using a jack if necessary. Install PPF differential mounting spacer (if removed). Tighten PPF/differential mounting spacer bolts to 28-38 ft. lbs. (38-52 N.m).
2. Install PPF blot sleeves to PPF. Install PPF to transmission, and tighten bolts by hand.

Install PPF to differential, and tighten bolts by hand. Ensure PPF-to-differential reamer bolt and sleeve are properly installed into the forward hole. See **Fig. 7**.

- When PPF is properly aligned between transmission and differential, tighten all long mounting bolts to specification. See **TORQUE SPECIFICATIONS**. To complete installation, reverse removal procedure. Fill all fluids to correct levels. Prime fuel system before attempting to start engine. See **FUEL PRESSURE RELEASE & PRIMING**. Bleed cooling system. See **COOLING SYSTEM BLEEDING**.

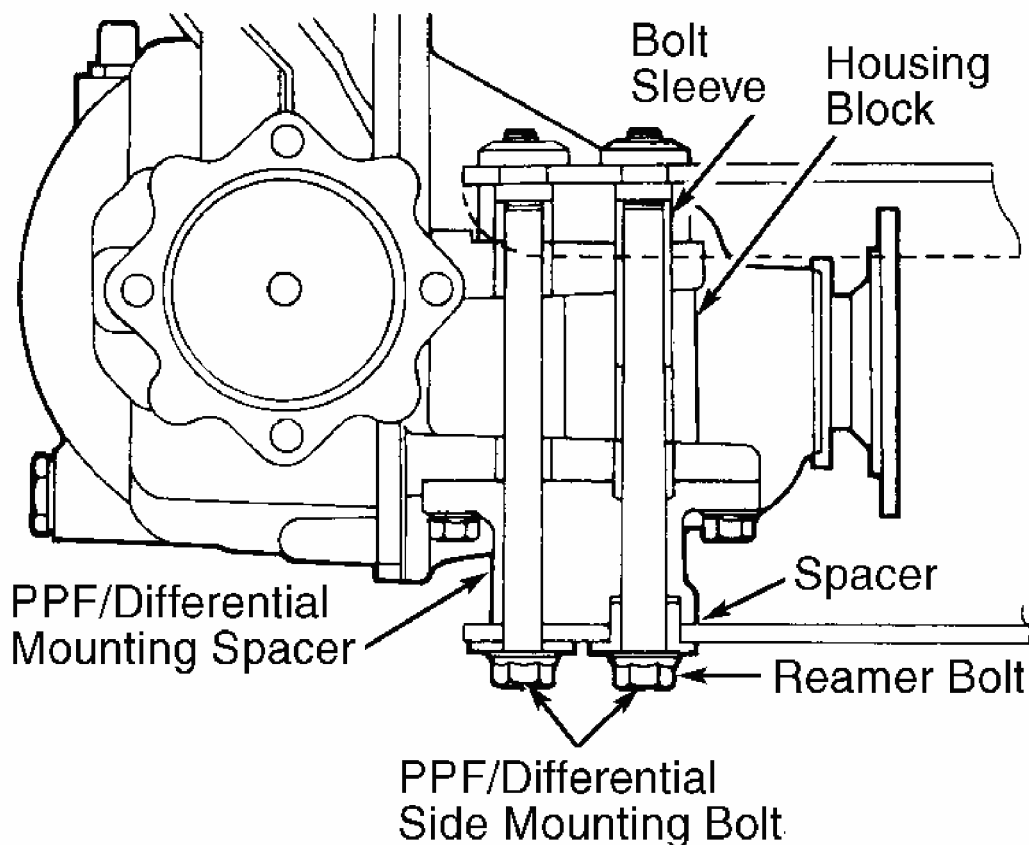

G91I01838

Fig. 7: Locating PPF-To-Differential Reamer Bolt, Sleeve & Spacer (Miata)
 Courtesy of MAZDA MOTORS CORP.

Removal (Protege)

- Release fuel pressure. See **FUEL PRESSURE RELEASE & PRIMING**. Disconnect negative battery cable. Mark and remove hood. Drain cooling system.
- Remove air cleaner assembly and intake air duct. Remove battery and battery box. Disconnect throttle cable, and remove bracket. Remove radiator hoses. Disconnect transmission cooler lines (A/T models). Remove radiator and cooling fans.

1999 Mazda MX-5 Miata

1999-2000 ENGINES 1.8L 4-Cylinder

3. Note locations and disconnect all necessary electrical connectors, ground wires, vacuum hoses, fuel lines, heater hoses and control cables. Remove fuse box.
4. Remove all drive belts. Remove power steering pump with hoses attached, and suspend aside. Remove A/C compressor with hoses attached, and suspend aside.
5. Raise and support vehicle. Drain engine and transaxle. Remove shift linkage, control cables, hydraulic lines and electrical connectors from transaxle. Disconnect exhaust pipe flange from WU/TWC.
6. Remove wheels. Remove axle shaft nuts from hubs. Disconnect stabilizer bar from lower control arms. Separate lower ball joints and steering tie-rod ends from steering knuckles.
7. Pry axle shafts out of transaxle. Remove and discard circlip from axle shaft. For further information on axle shafts removal and installation, see appropriate AXLE SHAFTS article in DRIVE AXLES.
8. Remove transaxle mount nuts from crossmember, and loosen crossmember bolts. See **Fig. 8**. Lower vehicle and attach engine lifting device to engine. Support engine and remove engine mounting crossmember. Remove engine mounts No. 4 and 3. Remove engine mounts No. 1 and 2. Remove engine and transaxle assembly from top of vehicle.

1999 Mazda MX-5 Miata

1999-2000 ENGINES 1.8L 4-Cylinder

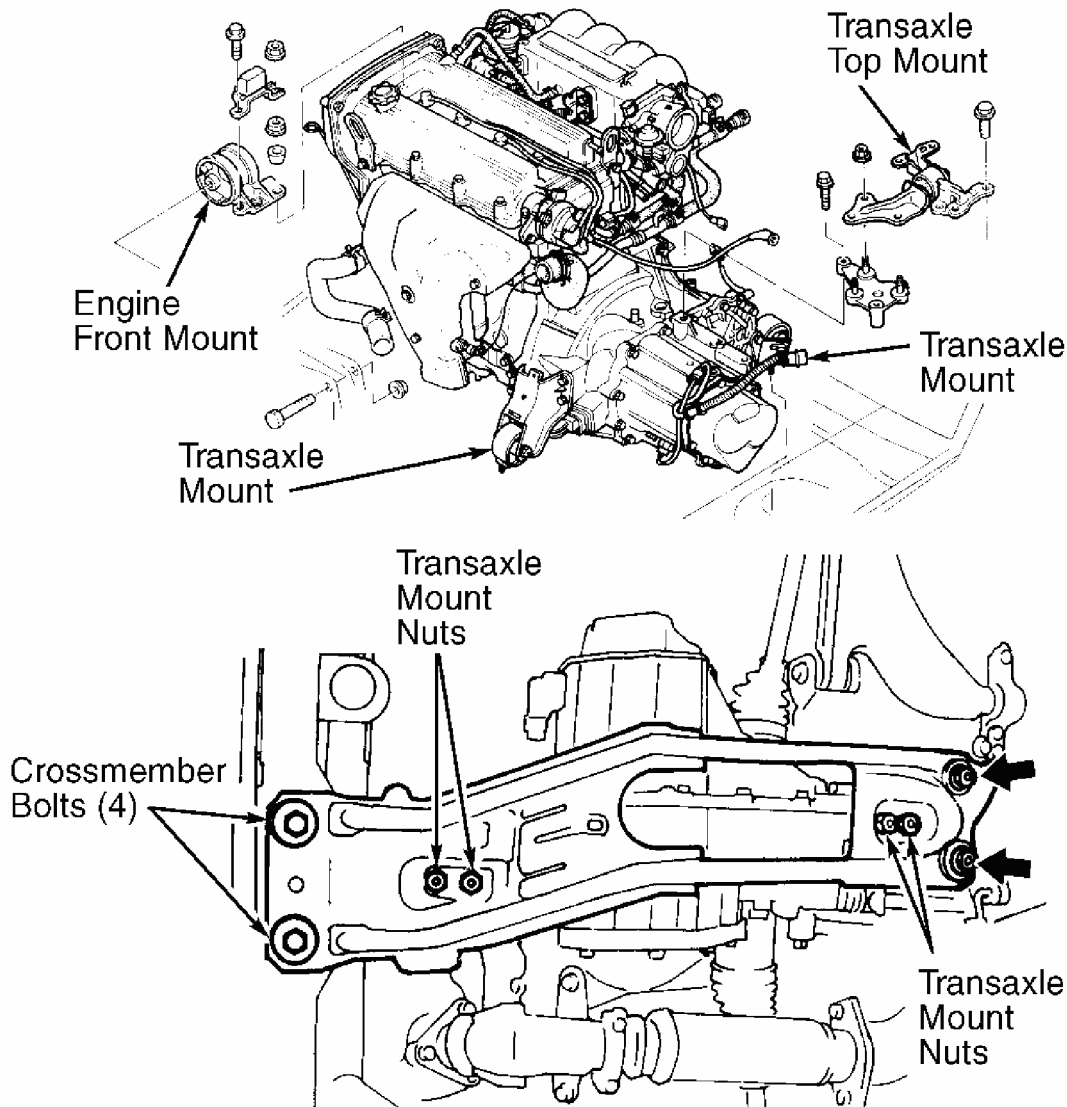

G91C01840

Fig. 8: Removing Engine Mounts (Protege)
Courtesy of MAZDA MOTORS CORP.

Installation

1. To install, reverse removal procedure. Install engine mount No. 1 and No. 2. Install engine mount No. 3 and No. 4. Install engine mounting crossmember. See **Fig. 8** and **Fig. 9**.
2. To complete installation, reverse removal procedure. Tighten bolts and nuts to specifications. See **TORQUE SPECIFICATIONS**. Fill all fluids to correct levels. Prime fuel system before attempting to start engine. See **FUEL PRESSURE RELEASE & PRIMING**. Bleed cooling system. See **COOLING SYSTEM BLEEDING**.

1999 Mazda MX-5 Miata

1999-2000 ENGINES 1.8L 4-Cylinder

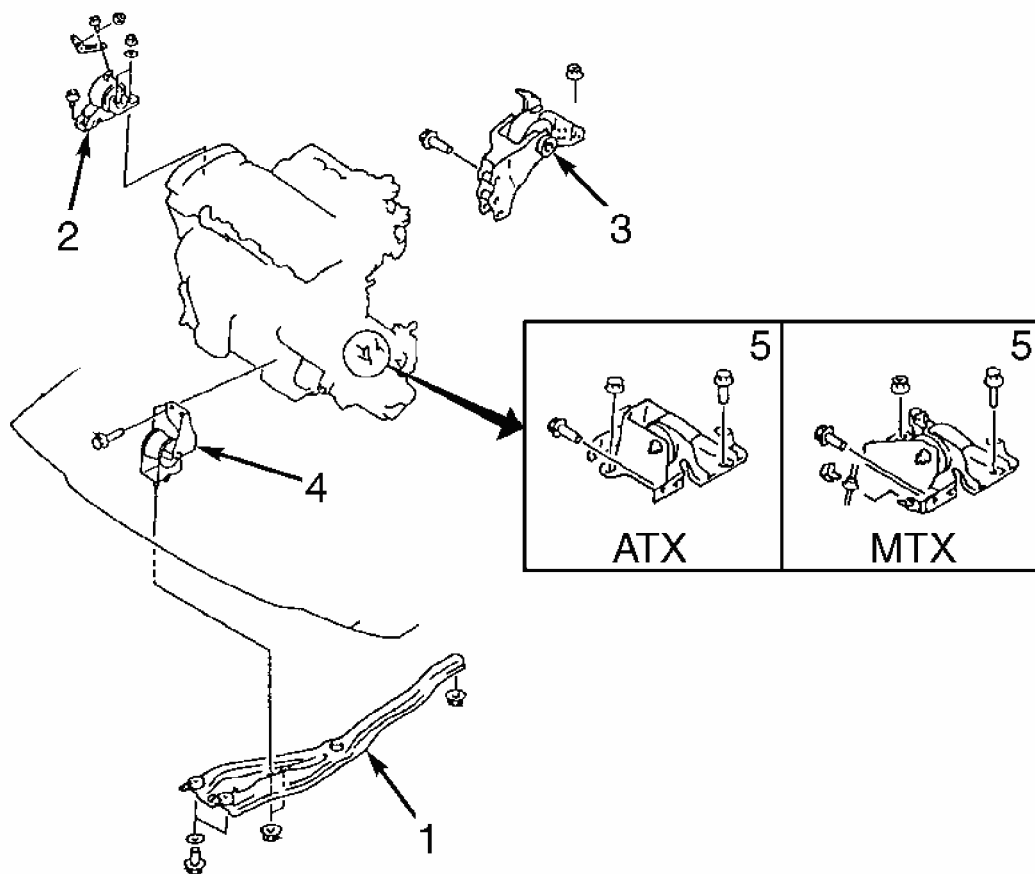

1. Crossmember
2. No. 1 Engine Mount
3. No. 4 Engine Mount

4. No. 2 Engine Mount
5. No. 3 Engine Mount

G00008425

Fig. 9: Identifying Engine Mounts (Protege)
Courtesy of MAZDA MOTOR CORP.

INTAKE MANIFOLD

Removal

1. Release fuel pressure. See **FUEL PRESSURE RELEASE & PRIMING**. Disconnect negative battery cable. Drain cooling system. Remove air cleaner assembly and intake air duct. Mark and disconnect coolant hoses, vacuum hoses and electrical connectors from intake manifold, dynamic chamber and throttle body.
2. Disconnect throttle cable, and remove bracket. Remove fuel lines from fuel rail and pressure regulator. Remove throttle body. On Protege, remove intake manifold and dynamic chamber support brackets.

1999 Mazda MX-5 Miata

1999-2000 ENGINES 1.8L 4-Cylinder

3. On Miata, remove VICS solenoid valve and bracket. Disconnect EGR pipe. Remove fuel injectors/fuel rail assembly. Remove intake manifold and dynamic chamber.

Installation

1. Ensure all gasket surfaces are clean. Using NEW gaskets, ensure that convex side of the dynamic chamber and intake manifold gaskets are both facing intake manifold. Install intake manifold and dynamic chamber to cylinder head. Tighten manifold bolts/nuts evenly to specification, starting from center bolt and alternating outward. See **TORQUE SPECIFICATIONS**. Install support brackets.
2. To complete installation, reverse removal procedure. Tighten bolts/nuts evenly to specification, alternating from top to bottom. See **TORQUE SPECIFICATIONS**. Ensure throttle cable has .04-.12" (1-3 mm) free play. Ensure injectors twist freely and are not cocked in insulator "O" rings. Refill with coolant, and bleed system. See **COOLING SYSTEM BLEEDING**.

EXHAUST MANIFOLD

Removal & Installation

1. Remove air cleaner and air intake duct. Disconnect oxygen sensors. Remove heat shield. Disconnect exhaust pipe flange from WU/TWC. Remove WU-TWC. Disconnect EGR pipe. On Miata models, remove windshield washer tank. On Protege models, remove bolt "A" on coolant by-pass pipe. See **Fig. 10**. On all models, remove exhaust manifold.
2. To install, reverse removal procedure. Ensure all mating surfaces are clean. Install exhaust manifold using NEW gasket, with convex side of gasket facing exhaust manifold. Tighten manifold bolts/nuts evenly to specification, starting from center and alternating outward. See **TORQUE SPECIFICATIONS**.

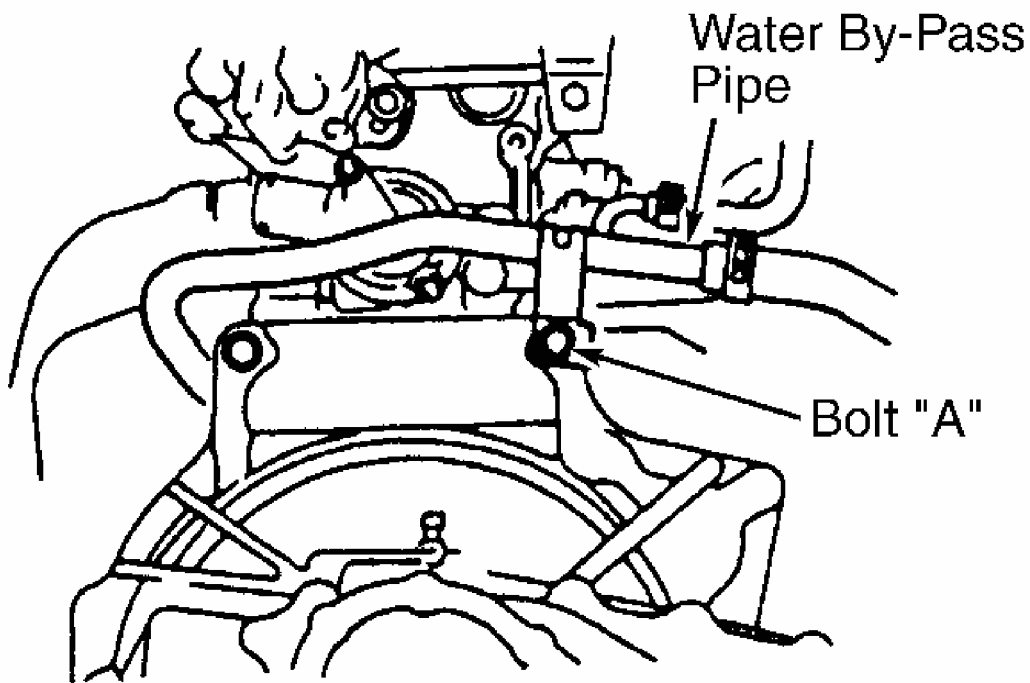

G00008430

Fig. 10: Locating Coolant By-Pass Pipe Bolt "A" (Protege)
Courtesy of MAZDA MOTOR CORP.

VALVE COVER

Removal (Miata)

Remove valve cover bolts in 2-3 steps, in reverse order of tightening sequence. See **Fig. 11**.
Remove valve cover.

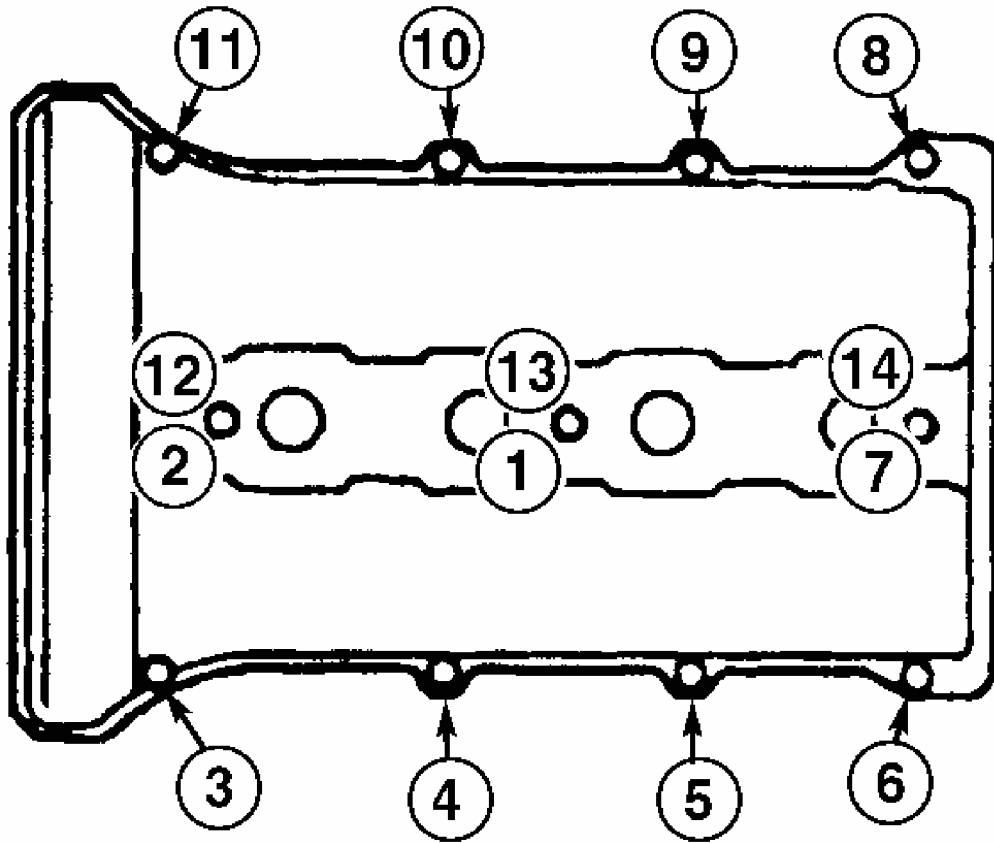

G00009911

Fig. 11: Valve Cover Bolt Tightening Sequence (Miata)
Courtesy of MAZDA MOTOR CORP.

1999 Mazda MX-5 Miata

1999-2000 ENGINES 1.8L 4-Cylinder

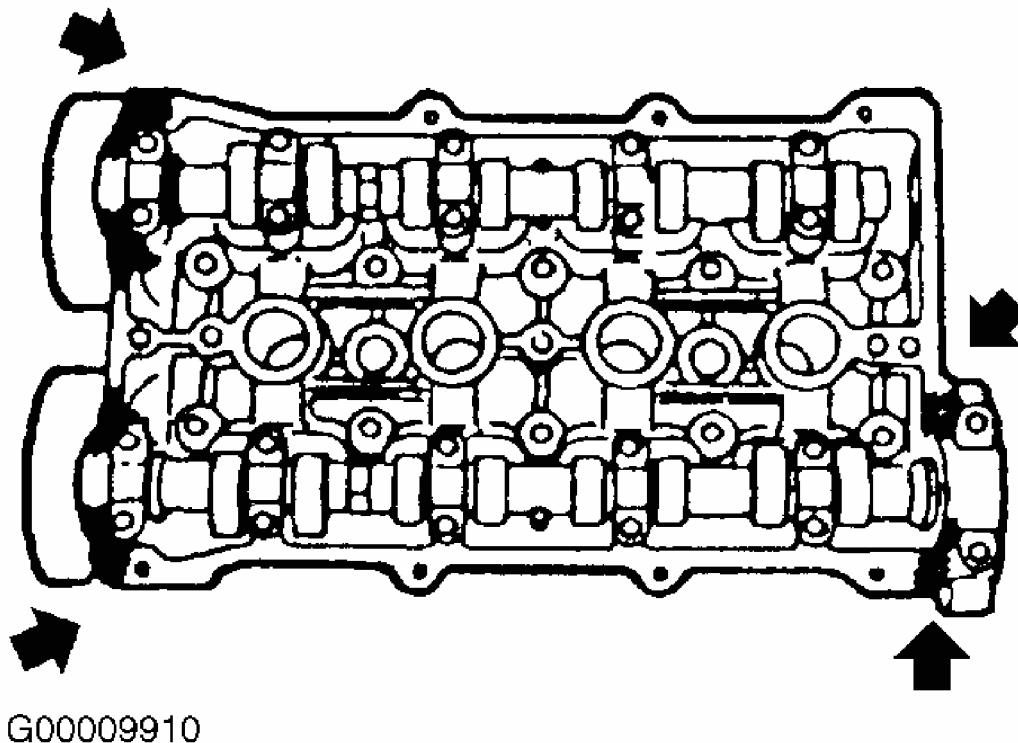

Fig. 12: Applying Sealant To Cylinder Head (Miata)
Courtesy of MAZDA MOTOR CORP.

Installation

Ensure mating surfaces are clean. Install NEW gasket on valve cover. Apply silicone sealant to cylinder head as shown. See **Fig. 12**. Hand tighten bolt No. 11 first, then tighten all bolts to specification, in 2-3 steps, and in sequence. See **Fig. 11**.

Removal (Protege)

Remove valve cover bolts in 2-3 steps, in the sequence shown. See **Fig. 13**. Remove valve cover.

1999 Mazda MX-5 Miata

1999-2000 ENGINES 1.8L 4-Cylinder

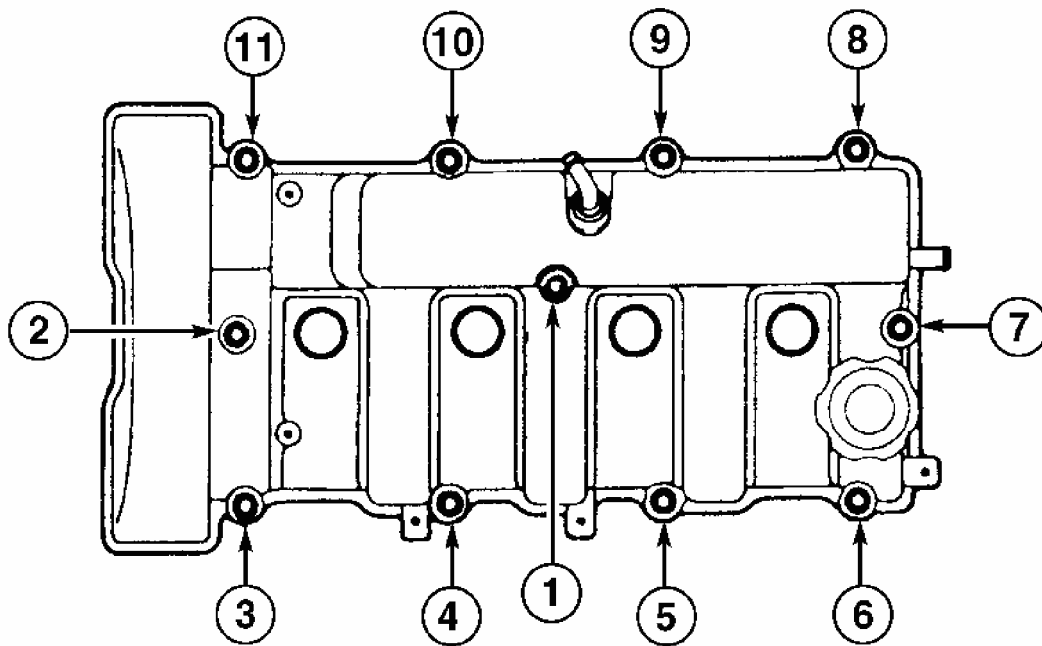

G00009907

Fig. 13: Valve Cover Bolt Loosening Sequence (Protege)
Courtesy of MAZDA MOTOR CORP.

Installation

Ensure mating surfaces are clean. Install NEW gasket on valve cover. Apply silicone sealant to cylinder head as shown. See [Fig. 14](#). Tighten all bolts to specification, in 2-3 steps, and in sequence. See [Fig. 15](#).

1999 Mazda MX-5 Miata

1999-2000 ENGINES 1.8L 4-Cylinder

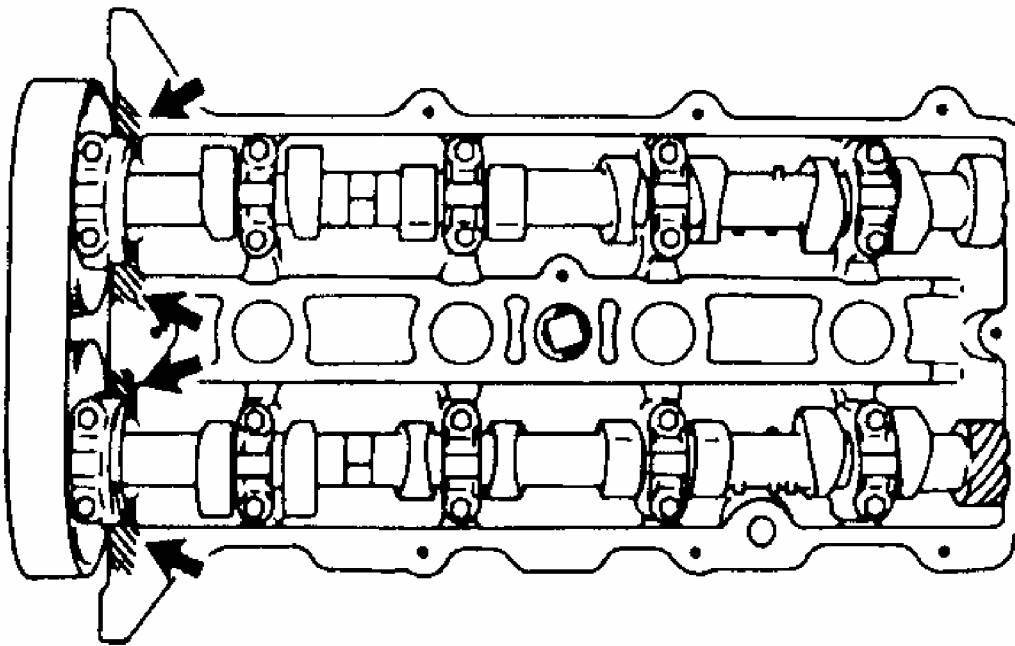

G00009915

Fig. 14: Applying Sealant To Cylinder Head (Protege)
Courtesy of MAZDA MOTOR CORP.

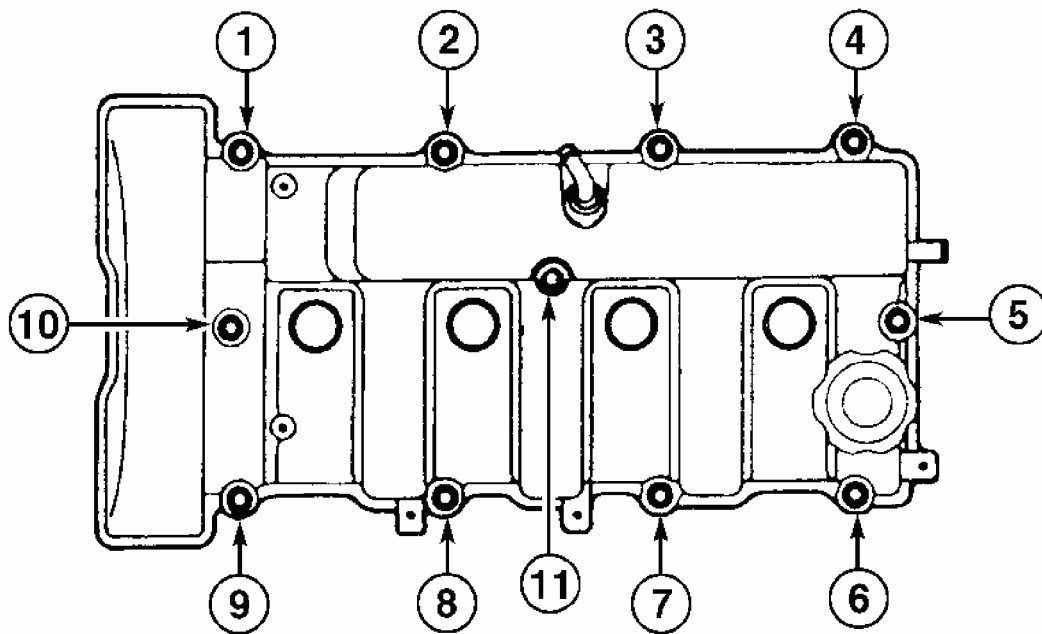

G00009916

Fig. 15: Valve Cover Bolt Tightening Sequence (Protege)
 Courtesy of MAZDA MOTOR CORP.

CYLINDER HEAD

Removal

1. Disconnect negative battery cable. Remove air cleaner and intake air duct. Release fuel pressure. See **FUEL PRESSURE RELEASE & PRIMING**. Drain coolant. Note locations and disconnect all necessary electrical connectors, ground wires, vacuum hoses, fuel lines, coolant hoses and control cables. Plug all fuel lines to avoid leakage.
2. Remove timing belt. See **TIMING BELT**. On Protege models, remove power steering pump and bracket with hoses attached, and suspend aside. On all models, disconnect exhaust pipe flange from WU/TWC. Remove exhaust manifold heat shield.
3. Disconnect throttle cable, and remove bracket. Remove ignition coil. Remove intake and exhaust manifold support brackets. Remove camshaft sprockets. Mark camshaft bearing caps for installation reference. Loosen bearing cap bolts, a few turns at a time, in the sequence shown. See **Fig. 16** or **Fig. 17**. Remove camshafts. Loosen cylinder head bolts, in 3 steps, and in sequence. See **Fig. 18**. Remove cylinder head assembly.

1999 Mazda MX-5 Miata

1999-2000 ENGINES 1.8L 4-Cylinder

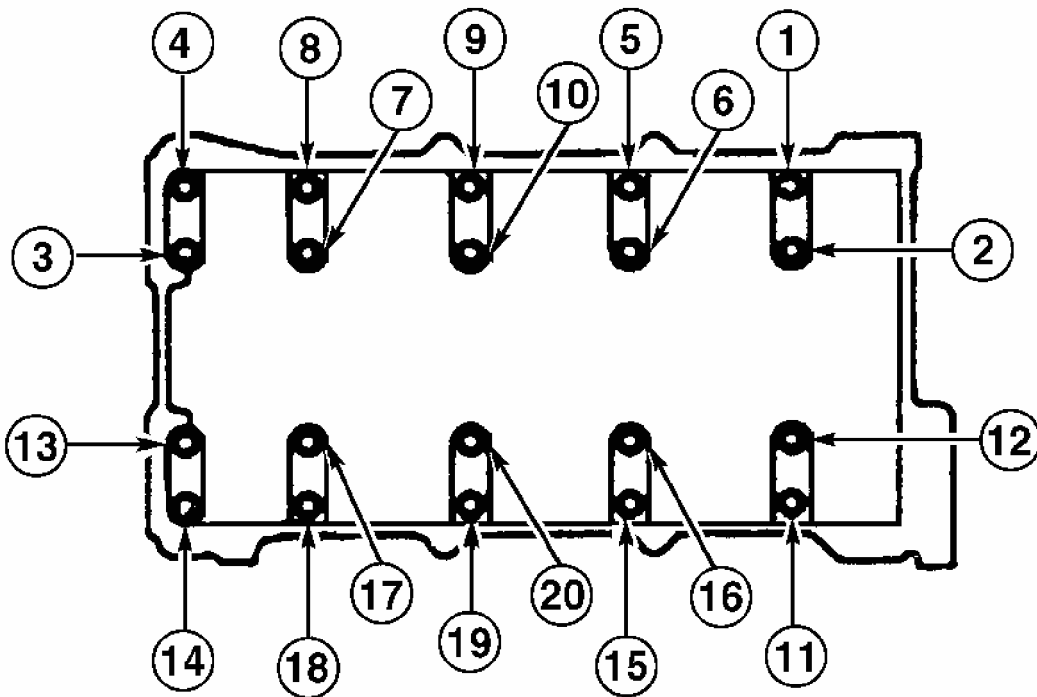

G00009917

Fig. 16: Camshaft Bearing Cap Bolt Loosening Sequence (Miata)
Courtesy of MAZDA MOTOR CORP.

1999 Mazda MX-5 Miata

1999-2000 ENGINES 1.8L 4-Cylinder

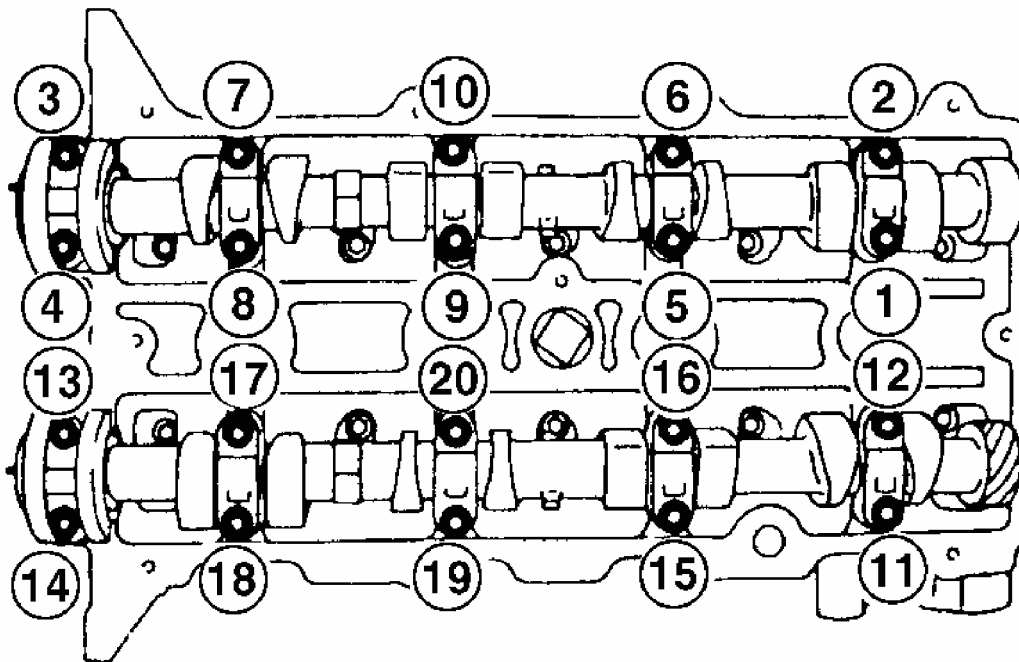

G00008434

Fig. 17: Camshaft Bearing Cap Bolt Loosening Sequence (Protege)
Courtesy of MAZDA MOTOR CORP.

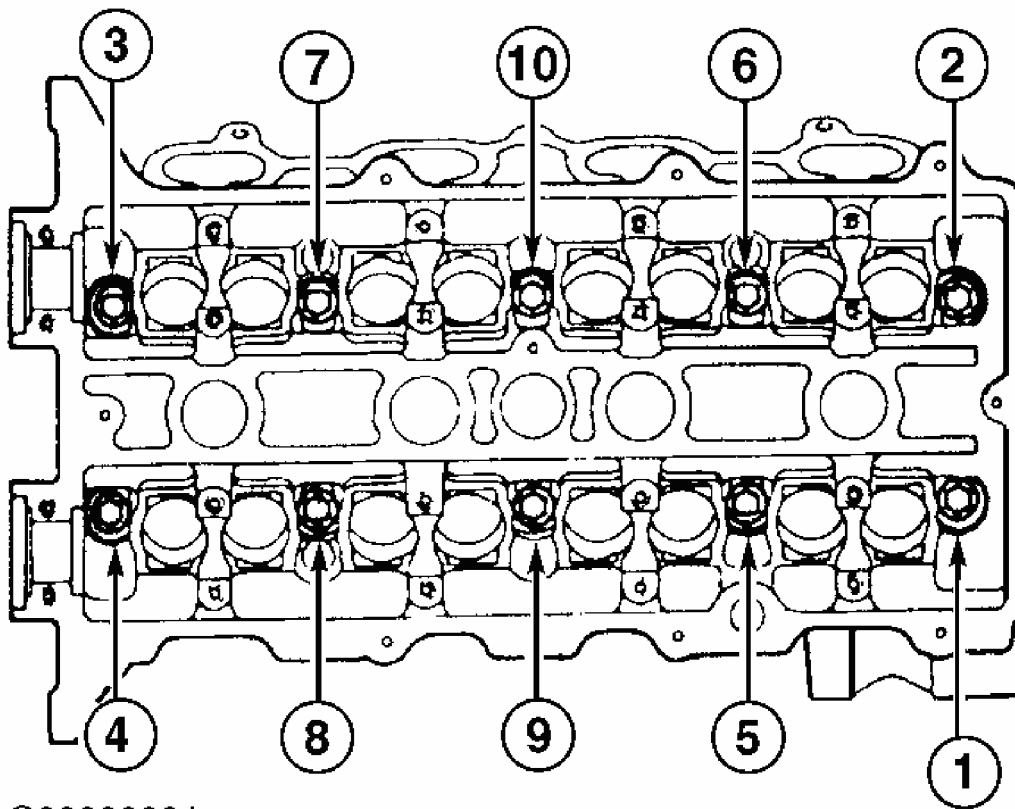

G00009901

Fig. 18: Cylinder Head Bolt Loosening Sequence
 Courtesy of MAZDA MOTOR CORP.

Inspection

Carefully clean carbon and gasket material from all mating surfaces. Measure the length of each head bolt, and replace if not within specification. See **CYLINDER HEAD** table under ENGINE SPECIFICATIONS. Clean threads of cylinder head bolts. Use a tap to clean threads in engine block. Check cylinder head for warpage. Resurface or replace if not within specification. Check camshaft thrust clearance. Check valve train components. Replace or resurface components if they are not within specification. See **CYLINDER HEAD** and **VALVES & VALVE SPRINGS** tables under ENGINE SPECIFICATIONS.

Installation

1. Install NEW cylinder head gasket. Install cylinder head. Tighten bolts to specification, in 2-3 steps, and in sequence. See **Fig. 19**. See **TORQUE SPECIFICATIONS**.
2. Apply oil to camshaft journals, and install camshafts so that lobes are pointing up on No. 1 and No. 3 cylinders, as shown. See **Fig. 20**. Apply silicone sealant to cylinder

head mating surfaces of camshaft caps No. 1 and No. 6. Install camshaft caps in original locations. On Protege, hand tighten bolts No. 2, 4, 5, and 7. See **Fig. 21**. On all models, tighten camshaft cap bolts to specification, in 2-3 steps, and in sequence. See **Fig. 21** or **Fig. 22**. See **TORQUE SPECIFICATIONS**.

3. Apply oil to camshaft oil seal. Using Seal Driver (49-T028-302 for Miata, or 49-B014-001 for Protege), install camshaft oil seal. Rotate camshafts until camshaft dowel pins face straight up. On Miata, install camshaft sprockets with the "I" mark (intake side), or "E" mark (exhaust side) facing straight up. See **Fig. 23**. On Protege, install camshaft sprockets with the dowel pins straight up and the "I" and "E" facing each other. See **Fig. 24**. Hold camshafts by using a wrench on the cast hexagon on camshafts, and tighten sprocket lock bolts to specification. See **TORQUE SPECIFICATIONS**. To complete installation, reverse removal procedure. Fill cooling system with coolant and bleed system. See **COOLING SYSTEM BLEEDING**.

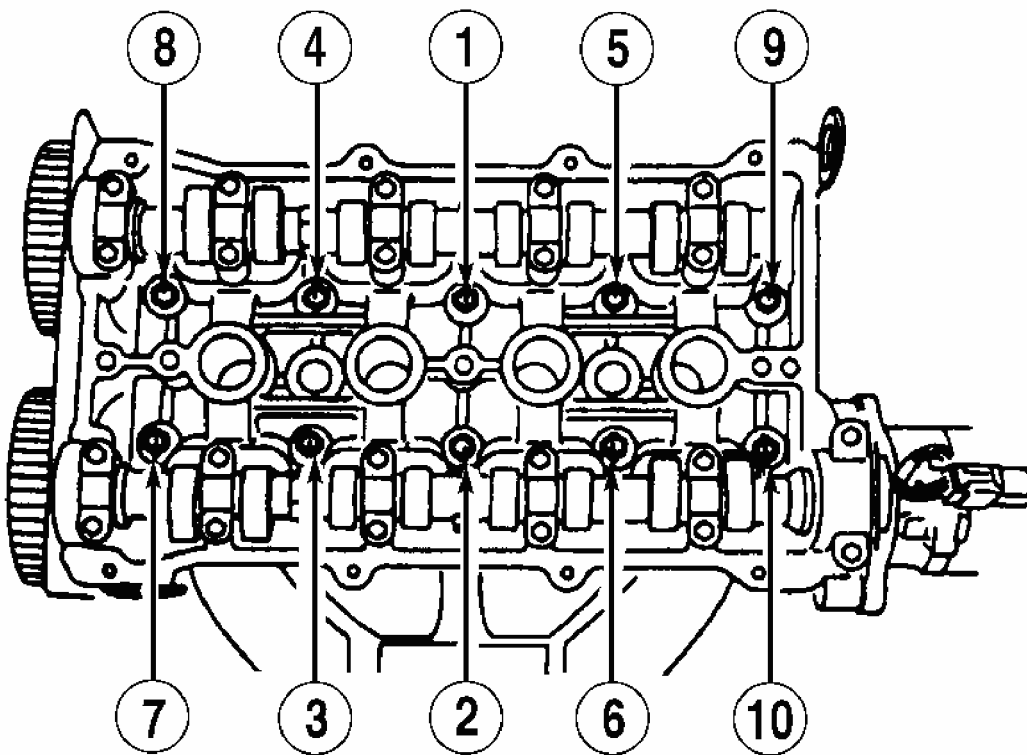

G94E47500

Fig. 19: Cylinder Head Bolt Tightening Sequence
 Courtesy of MAZDA MOTORS CORP.

1999 Mazda MX-5 Miata

1999-2000 ENGINES 1.8L 4-Cylinder

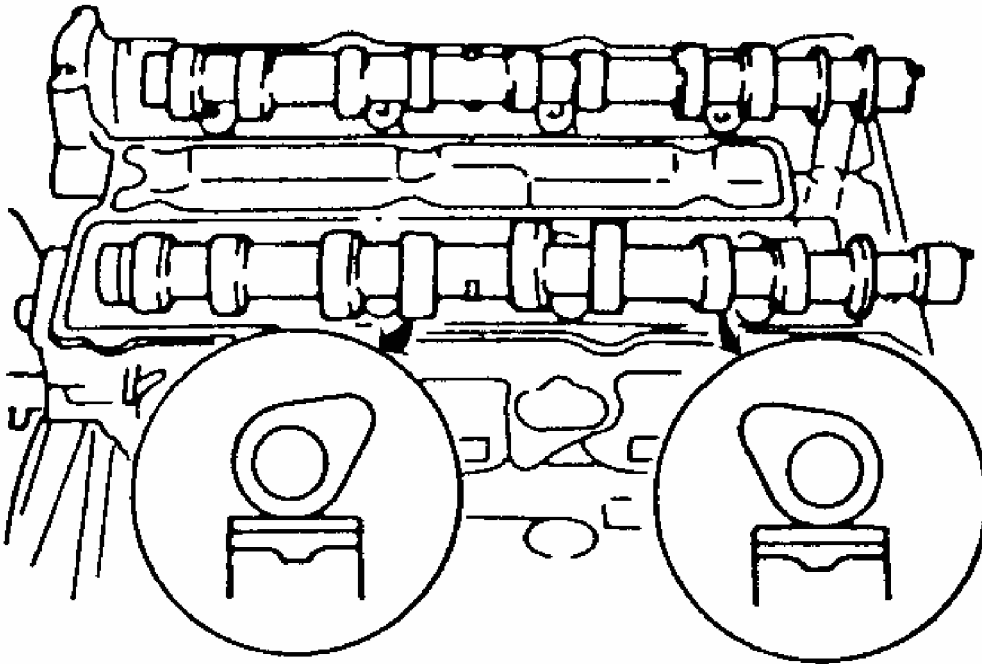

NO. 3 CYLINDER

NO. 1 CYLINDER

G00009905

Fig. 20: Positioning Camshaft Lobes
Courtesy of MAZDA MOTOR CORP.

1999 Mazda MX-5 Miata

1999-2000 ENGINES 1.8L 4-Cylinder

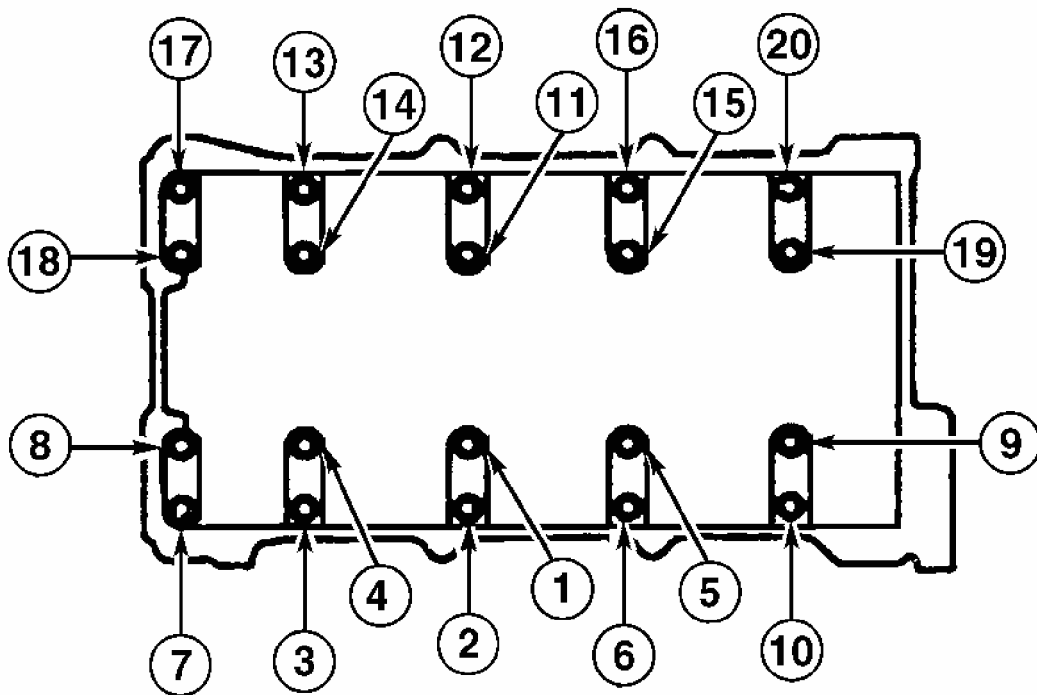

G00009912

Fig. 21: Camshaft Bearing Cap Bolt Tightening Sequence (Miata)
Courtesy of MAZDA MOTOR CORP.

1999 Mazda MX-5 Miata

1999-2000 ENGINES 1.8L 4-Cylinder

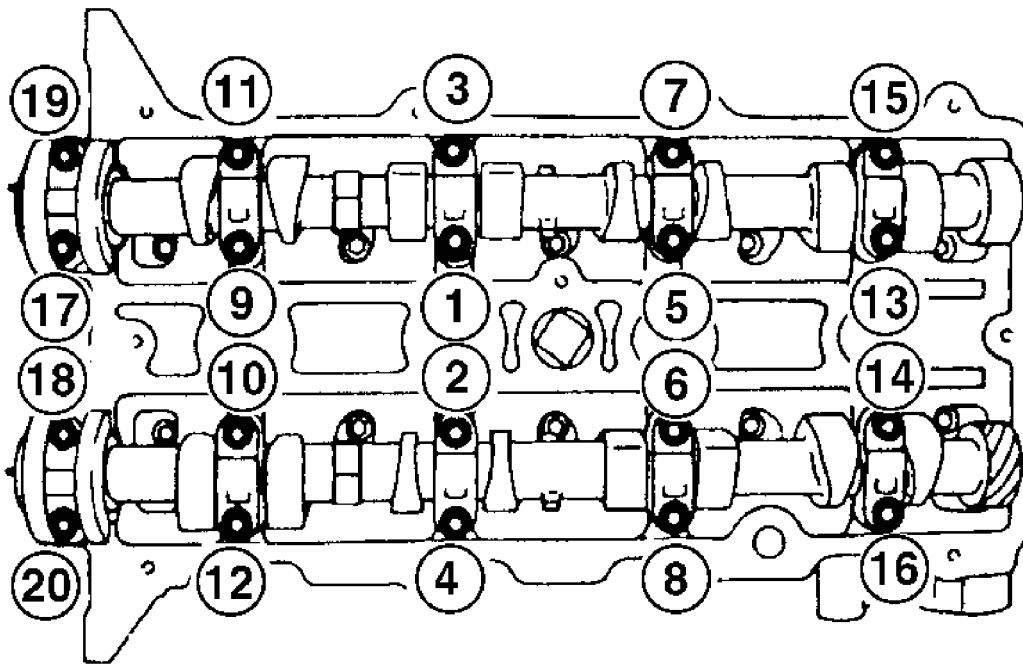

G00009906

Fig. 22: Camshaft Bearing Cap Bolt Tightening Sequence (Protege)
Courtesy of MAZDA MOTOR CORP.

1999 Mazda MX-5 Miata

1999-2000 ENGINES 1.8L 4-Cylinder

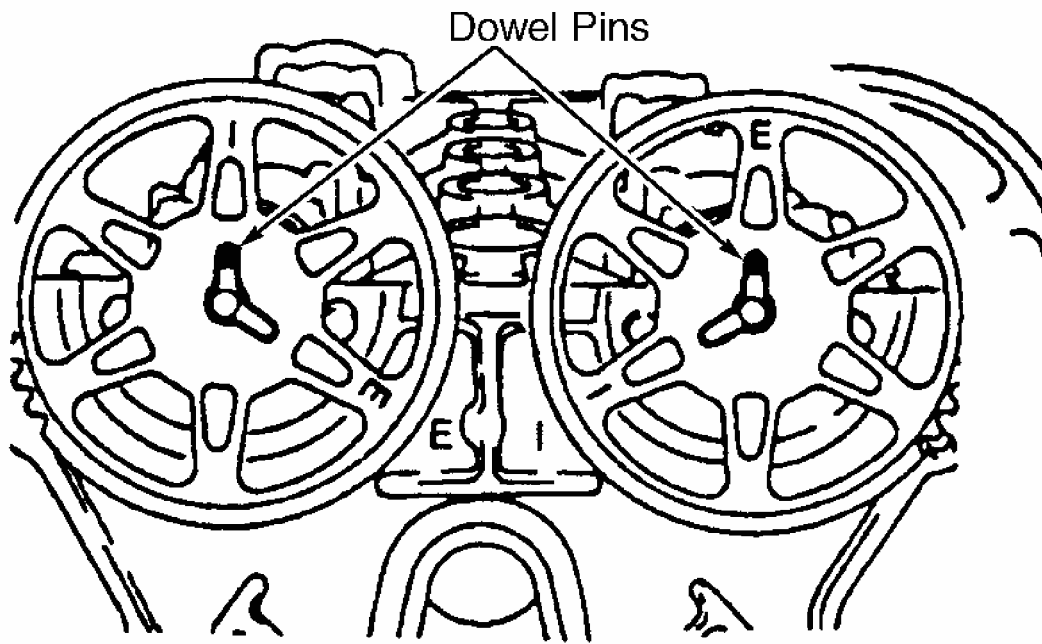

G00009913

Fig. 23: Installing Camshaft Sprockets (Miata)
Courtesy of MAZDA MOTOR CORP.

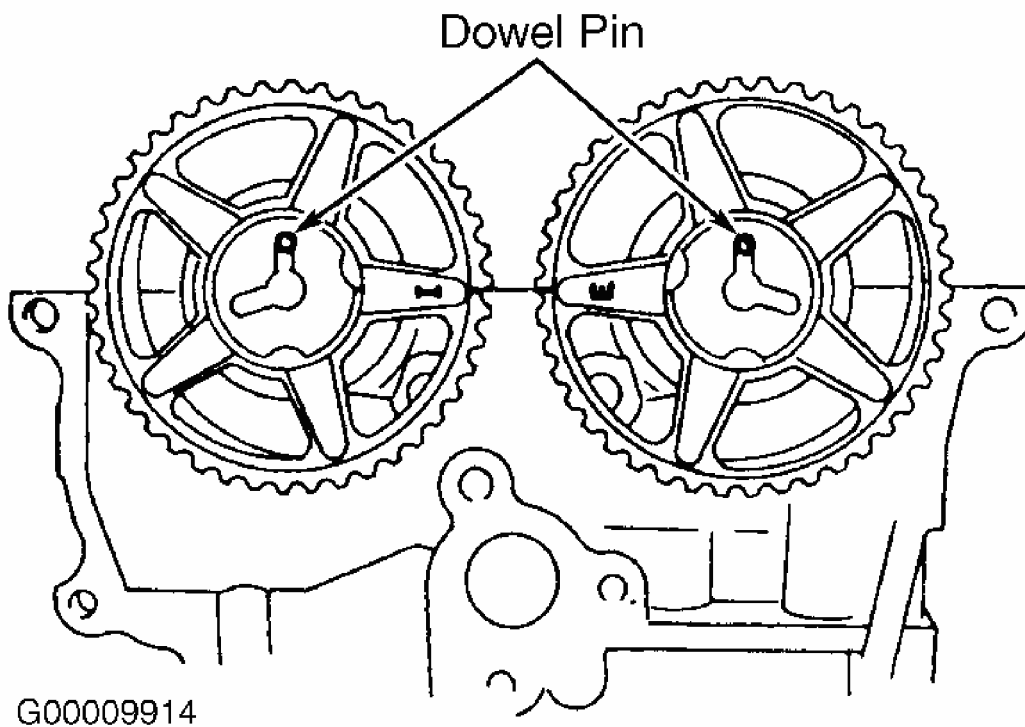

Fig. 24: Installing Camshaft Sprockets (Protege)
 Courtesy of MAZDA MOTOR CORP.

CRANKSHAFT FRONT SEAL

Removal

Disconnect negative battery cable. Remove drive belts and water pump pulley. Remove crankshaft pulley, timing belt covers and timing belt. See **TIMING BELT**. Remove crankshaft sprocket and Woodruff key. Remove crankshaft seal.

Installation

1. Apply oil to seal lip. Using a hammer and Seal Driver (49-B014-001) for Miata, or (49-H010-401) for Protege, tap seal into oil pump body until flush with edge of pump body. DO NOT bottom seal in pump body. Install crankshaft sprocket and Woodruff key with tapered side of key facing toward oil pump body.
2. Install timing belt. See **TIMING BELT**. Install timing belt covers, pulleys and drive belts. To complete installation, reverse removal procedure.

TIMING BELT

NOTE: For 1999-2000 vehicles, the replacement interval is 60,000 miles

except for vehicles registered in California, Connecticut, Delaware, Maine, Maryland, Massachusetts, New Hampshire, New Jersey, New York, Pennsylvania, Rhode Island, Vermont, Virginia and Washington D.C. For these states, inspect timing belt at 60,000 and 90,000 miles, and replace timing belt at 105,000 miles.

Removal (Miata)

1. Disconnect negative battery cable. Drain cooling system. Remove air cleaner and intake air duct. Remove upper radiator hose and by-pass hoses from thermostat housing. Remove camshaft and crankshaft position sensors. Remove ignition coil. Remove spark plugs.
2. Remove drive belts and water pump pulley. Remove valve cover. See **VALVE COVER**. Position No. 1 cylinder at TDC of compression stroke. Hold crankshaft pulley stationary using Crankshaft Locking Tool (49-D011-102), and remove crankshaft pulley bolts. Remove crankshaft pulley and plate. Remove crankshaft sprocket lock bolt and sprocket boss.
3. Remove upper, center and lower timing belt covers. If timing belt is to be reused, mark timing belt rotation direction. Ensure timing marks on camshaft and crankshaft sprockets are aligned. See **Fig. 25**. Loosen timing belt tensioner lock bolt, and move tensioner away from belt. Retighten lock bolt. Remove timing belt.

Inspection

Check timing belt for cracks, peeling, abrasion, oil or other damage. Check tensioner bearing for looseness or roughness of rotation. Measure tensioner spring free length. If not within specification, replace spring. Free length should be 2.33" (59.2 mm). Replace parts as necessary.

Installation

1. Ensure all timing marks are aligned. Install timing belt around crankshaft sprocket first, then working counterclockwise, install belt around idler pulley and camshaft sprockets. Ensure there is no slack in timing belt on idler pulley side and between camshaft sprockets. Install crankshaft sprocket boss and lock bolt. For proper timing belt tension adjustment, rotate crankshaft 1 5/6 times, and align sprocket mark with tensioner set mark. See **Fig. 26**. Remove crankshaft sprocket boss and lock bolt.
2. Install tensioner spring with the closed end to the hook pin. Loosen tensioner lock bolt to apply tension to timing belt. Tighten tensioner lock bolt. Install crankshaft sprocket boss and lock bolt. Rotate crankshaft 2 1/6 times, and position pin in sprocket boss straight up. Ensure all timing marks are aligned. See **Fig. 25**. Measure timing belt deflection between camshaft sprockets using 22 lbs. (10 kg) of pressure. See **Fig. 27**. Timing belt deflection should be .35-.45" (9.0-11.5 mm). See **TIMING BELT DEFLECTION** table.

3. Install NEW valve cover gasket on valve cover. Apply silicone sealant to cylinder head as shown. See **Fig. 12**. Install valve cover. Hand tighten bolt No. 11 first, then tighten all bolts to specification in 2-3 steps, and in sequence. See **Fig. 11**. To complete installation, reverse removal procedure. Tighten nuts and bolts to specification. See **TORQUE SPECIFICATIONS**.

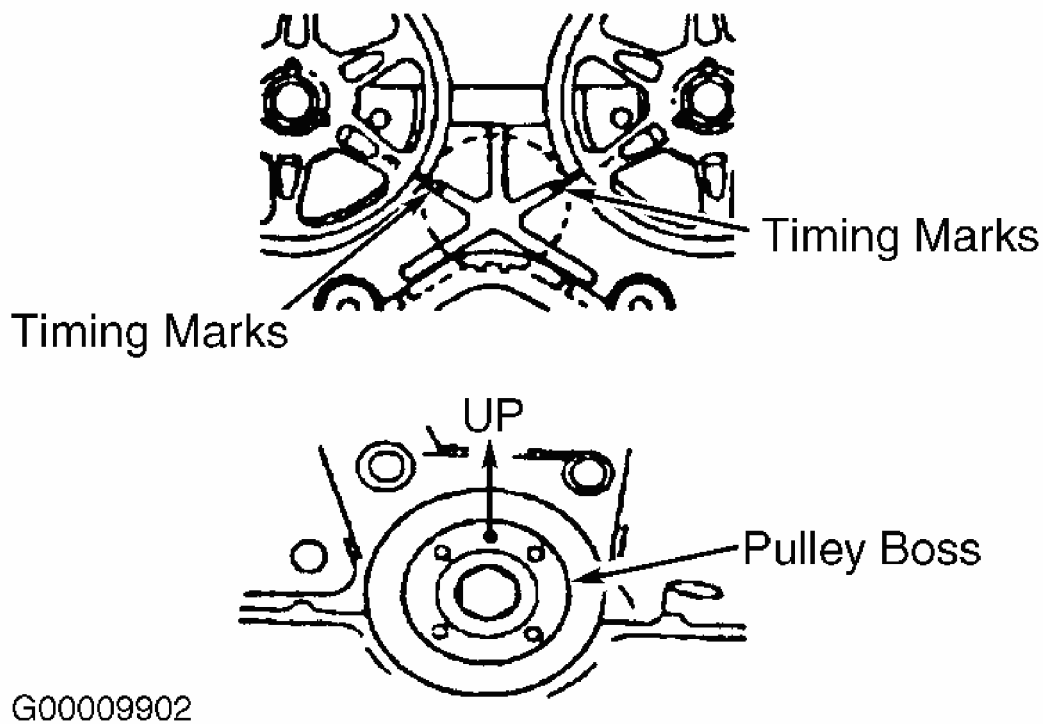

Fig. 25: Aligning Timing Belt Sprockets (Miata)
Courtesy of MAZDA MOTORS CORP.

1999 Mazda MX-5 Miata

1999-2000 ENGINES 1.8L 4-Cylinder

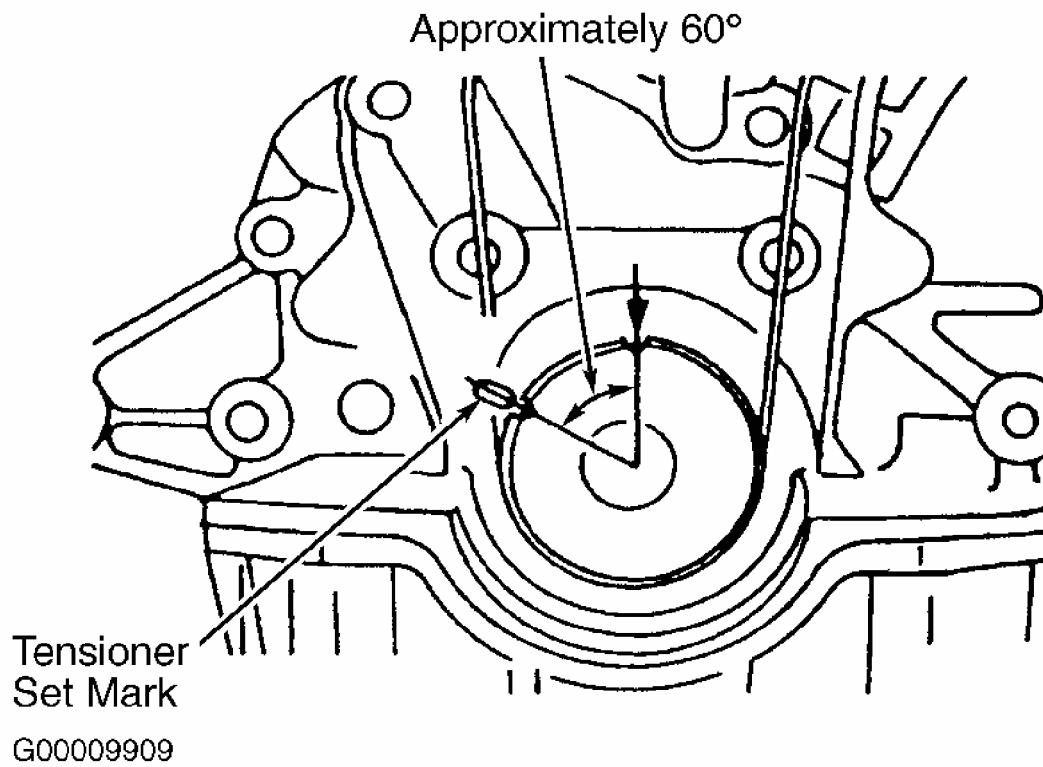

Fig. 26: Locating Tensioner Set Mark (Miata)
Courtesy of MAZDA MOTOR CORP.

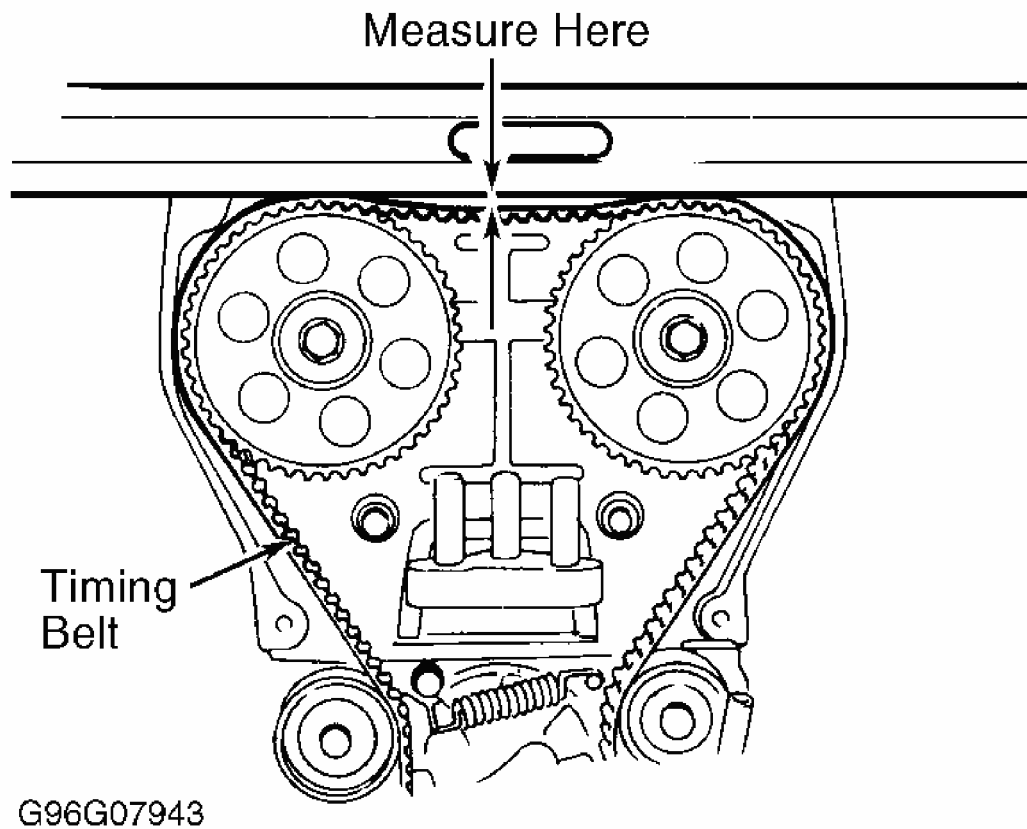

Fig. 27: Measuring Timing Belt Deflection
 Courtesy of MAZDA MOTORS CORP.

Removal (Protege)

1. Disconnect negative battery cable. Remove camshaft and crankshaft position sensors. Remove spark plugs. Remove drive belts and water pump pulley.
2. Position No. 1 cylinder at TDC of compression stroke. Hold crankshaft stationary using Crankshaft Holding Tools (49-E011-1A1 and 49-S120-710), and remove crankshaft pulley bolt, crankshaft pulley and guide plate.
3. Remove valve cover bolts 2-3 turns at a time, in sequence. See **Fig. 13**. Remove dipstick tube. Remove upper and lower timing belt covers. If timing belt is to be reused, mark timing belt rotation direction. Ensure timing marks on camshaft and crankshaft sprockets are aligned. See **Fig. 28**. Attach lifting device to engine, and support engine. Remove No. 3 engine mount. Using an Allen wrench, turn timing belt tensioner clockwise, and disconnect tensioner spring from hook pin. Remove timing belt.

Inspection

1999 Mazda MX-5 Miata

1999-2000 ENGINES 1.8L 4-Cylinder

Check timing belt for cracks, peeling, abrasion, oil or other damage. Check tensioner bearing for looseness or roughness of rotation. Measure tensioner spring free length. If not within specification, replace spring. Free length should be 1.44" (36.6 mm). Replace parts as necessary.

Installation

1. Ensure all timing marks are aligned. See **Fig. 28**. Install timing belt without any slack on the idler pulley side. Rotate crankshaft clockwise twice, and align timing marks.
2. Install tensioner spring with closed end to the hook pin in cylinder head. Tighten tensioner lock bolt. Rotate crankshaft clockwise 2 complete turns, and ensure all timing marks align. If timing marks are not aligned, remove belt, realign all timing marks, and repeat installation procedure.
3. Measure timing belt deflection with 22 lbs. (10 kg) of pressure applied to belt. See **Fig. 27**. Ensure timing belt deflection is within specification. See **TIMING BELT DEFLECTION** table.
4. Install engine mount No. 3. Install timing belt covers. Install dipstick tube. Install guide plate and crankshaft pulley. Install valve cover. See **VALVE COVER**. Install water pump pulley with "F" marks facing outward. To complete installation, reverse removal procedure. Tighten nuts and bolts to specification. See **TORQUE SPECIFICATIONS**.

TIMING BELT DEFLECTION

Application	(1) Deflection - In. (mm)
Miata & Protege	.35-.45 (9.0-11.5)

(1) Deflection measurement is with 22 lbs. (10 kg) of pressure applied to timing belt. See **Fig. 27**.

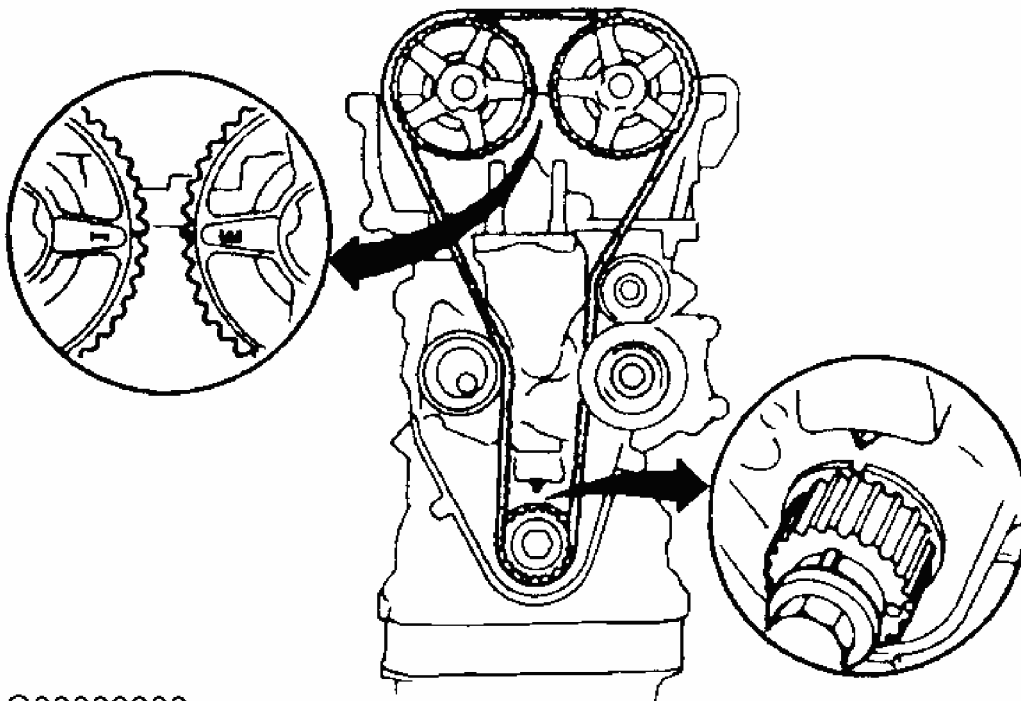

G00009908

Fig. 28: Aligning Timing Belt Sprocket Marks (Protege)
 Courtesy of MAZDA MOTOR CORP.

CAMSHAFT

Removal

Remove valve cover. See **VALVE COVER**. Remove timing belt. See **TIMING BELT**. Reference mark camshafts, caps and sprockets, and remove sprockets. Loosen camshaft bearing cap bolts in 2-3 steps, and in sequence. See **Fig. 16** or **Fig. 17**. Remove camshafts.

Inspection

Check camshaft end play. Check camshaft journal diameters and bearing clearances. Check camshaft lobes for wear. See **CAMSHAFT** table under ENGINE SPECIFICATIONS. If measurements are not within specifications, replace camshaft and/or cylinder head.

Installation

To install, reverse removal procedure. Apply silicone sealant to mating surface of cylinder head and camshaft oil seal cover cap. Tighten camshaft bearing cap bolts to specification, in 2-3 steps, and in sequence. See **Fig. 21** or **Fig. 22**. See **TORQUE SPECIFICATIONS**. Install timing belt. See **TIMING BELT**. Install valve cover. See **VALVE COVER**.

CRANKSHAFT REAR OIL SEAL**Removal & Installation**

1. Disconnect negative battery cable. Raise and support vehicle. Remove transmission/transaxle and flywheel. For automatic transmission removal procedure, see TRANSMISSION REMOVAL & INSTALLATION article in TRANSMISSION SERVICING. For manual transmission removal procedure, see appropriate article in CLUTCHES. On all models, pry out rear oil seal.
2. To install, apply oil to seal lip and push seal over crankshaft. Tap seal into rear cover until flush with edge of rear cover, then tap in an additional .019" (.5 mm). DO NOT bottom seal in cover.
3. Completely remove used sealant from flywheel bolts. Apply lock-type sealant to bolts, and install flywheel to crankshaft. Tighten bolts to specification, in a star-pattern sequence. See **TORQUE SPECIFICATIONS**. Install clutch assembly and tighten cover bolts to 13-19 ft. lbs. (18-26 N.m) in a star-pattern sequence (M/T models). Install transmission/transaxle.

WATER PUMP**Removal & Installation**

1. Disconnect negative battery cable. Drain engine coolant. Remove air cleaner and intake air duct. Position No. 1 cylinder at TDC of compression stroke. Remove timing belt. See **TIMING BELT**.
2. On Miata models, remove power steering pump with hoses attached, and suspend aside. On Protege models, remove power steering pump adjusting bracket. On all models, remove upper radiator hose and by-pass hoses from thermostat housing. Remove thermostat housing. Remove water pump.
3. Ensure gasket mating surfaces are clean. On Miata models, install NEW rubber seal with the bonding agent included. On Protege models, install NEW gasket with the sealing ring facing water pump. Install water pump and tighten bolts to specification. Install water pump pulley with the "F" marks facing outward.
4. To complete installation, reverse removal procedure. Tighten all nuts and bolts to specification. See **TORQUE SPECIFICATIONS**.

NOTE: For further information on cooling systems, see **SPECIFICATIONS** and **ELECTRIC COOLING FANS** articles in **ENGINE COOLING**.

OIL PAN

NOTE: On Miata, engine must be supported in order to remove oil pan.

1999 Mazda MX-5 Miata

1999-2000 ENGINES 1.8L 4-Cylinder

Removal & Installation (Miata)

1. Disconnect negative battery cable. Remove air cleaner and intake air duct. Raise and support vehicle. Remove left front wheel. Remove ABS wheel-speed sensor. Drain engine oil. Remove dipstick tube and "O" ring. Disconnect steering column intermediate shaft at steering rack coupling. See **Fig. 29**. Remove both front engine mount nuts. Attach lifting device to engine, and lift engine slightly.
2. Remove stabilizer link nut. Remove left strut lower mounting nut and bolt. Support engine mounting crossmember using transmission jack, and remove crossmember bolts. Slowly and carefully lower crossmember until clearance between oil pan and steering rack is about 5 inches. Remove oil pan bolts.
3. Being careful not to damage mating surfaces, use a separator tool to pry between oil pan and engine block. Remove oil pan. Remove oil pan baffle by prying it from engine block. See **Fig. 29**. DO NOT bend or deform oil pan or oil pan baffle mating surfaces. Replace oil pan or baffle if deformed. Clean sealant from oil pan, bolts, engine block and both sides of oil pan baffle.
4. To install, apply a bead of silicone sealant to baffle along mating surface, inside of bolt holes. Apply silicone sealant to the contact surfaces of 2 NEW half-round, rubber pan gaskets, and install onto oil pump body and rear cover. Apply a bead of silicone sealant to oil pan along mating surface, inside of bolt holes. Apply silicone sealant to threads of pan bolts, and install oil pan baffle and oil pan within 5 minutes of applying sealant. To complete installation, reverse removal procedure. Tighten bolts to specification. See **TORQUE SPECIFICATIONS**. Fill engine with oil to specification. See **ENGINE LUBRICATION SYSTEM** under ENGINE OILING.

1999 Mazda MX-5 Miata

1999-2000 ENGINES 1.8L 4-Cylinder

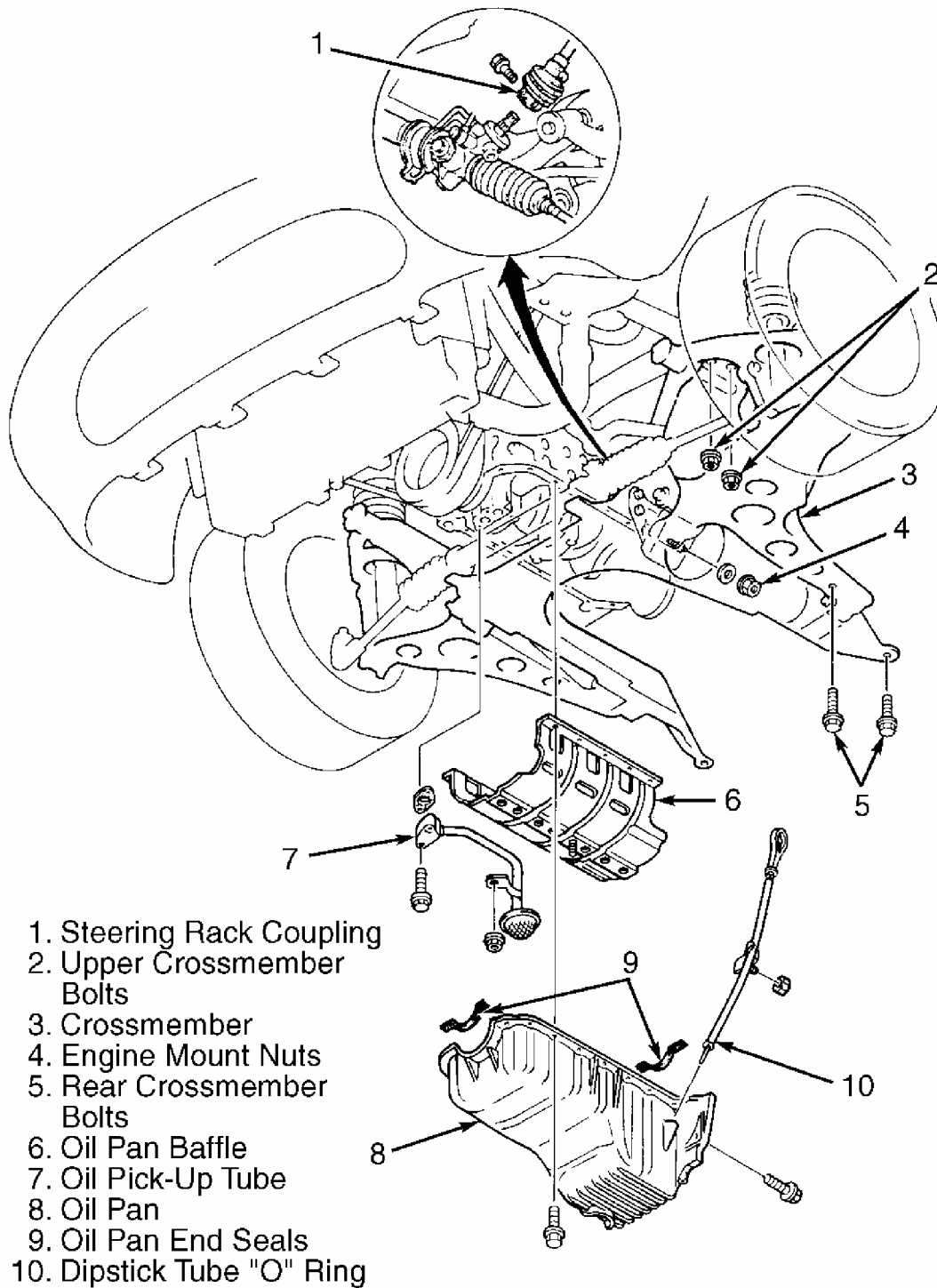

1. Steering Rack Coupling
2. Upper Crossmember Bolts
3. Crossmember
4. Engine Mount Nuts
5. Rear Crossmember Bolts
6. Oil Pan Baffle
7. Oil Pick-Up Tube
8. Oil Pan
9. Oil Pan End Seals
10. Dipstick Tube "O" Ring

G91D01845

Fig. 29: Removing Crossmember & Oil Pan (Miata)
Courtesy of MAZDA MOTORS CORP.

Removal & Installation (Protege)

1999 Mazda MX-5 Miata

1999-2000 ENGINES 1.8L 4-Cylinder

1. Disconnect negative battery cable. Raise and support vehicle. Drain engine oil. Disconnect exhaust pipe flange from WU/TWC. Remove oil pan bolts.
2. Screw a pan bolt into a welded nut hole on oil pan to make a small gap between oil pan and block. Being careful not to damage mating surfaces, insert a separator tool between pan and block, and remove oil pan. Clean all sealant from oil pan, bolts and engine block.

CAUTION: If reusing old oil pan bolts, remove old sealant from bolt threads. Failure to remove old sealant may result in cracked block at bolt holes.

3. To install, apply a bead of silicone sealant onto oil pan mating surface, inside of bolt holes. Apply silicone sealant onto threads of pan bolts, and install oil pan within 5 minutes of applying sealant. To complete installation, reverse removal procedure. Tighten all bolts to specification. See **TORQUE SPECIFICATIONS**. Fill engine with oil to specification. See **ENGINE LUBRICATION SYSTEM** under ENGINE OILING.

OVERHAUL

CYLINDER HEAD

Cylinder Head

Clean carbon and gasket material from all mating surfaces. Measure length of head bolts. Using a tap, clean cylinder head threads in cylinder block. Check cylinder head warpage. If warpage exceeds specification, resurface head. DO NOT exceed limit. See **CYLINDER HEAD** table under ENGINE SPECIFICATIONS. After resurfacing cylinder head, check cylinder head height. Replace cylinder head if height is less than minimum specification.

Valve Springs

Ensure valve spring free length, out-of-square and compressed length are within specification. See **VALVES & VALVE SPRINGS** table under ENGINE SPECIFICATIONS. Replace valve spring if necessary.

NOTE: Intake and exhaust valve stem seals are different. Exhaust seals are Green and have 2 ridges molded into top of seal. Intake seals are Grey and have one ridge molded into top of seal. Incorrect installation of valve stem seals will cause premature failure.

Valve Stem Oil Seals

1. On Miata, use Installer Set (49-L012-0A0A) to install valve stem seals. See **Fig. 30**. Adjust installer dimension "L" to seal depth of .720-.744" (18.3-18.9 mm). Using only

hand pressure, install seal until it contacts cylinder head. Lightly oil valve seal lip.

2. On Protege, use Installer Set (49-L012-0A0A) to install valve stem seals. See **Fig. 30**. Adjust installer dimension "L" to seal depth of .783" (19.9 mm). Using only hand pressure, install seal until it contacts cylinder head. Lightly oil valve seal lip.

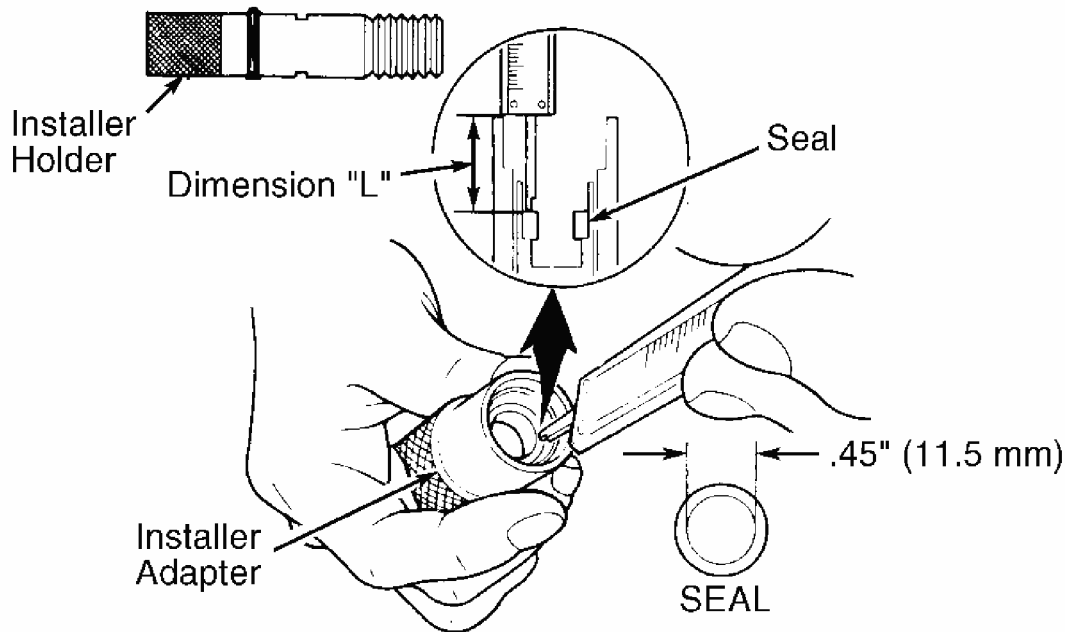

G94D47509

Fig. 30: Installing Valve Guide Seals
 Courtesy of MAZDA MOTORS CORP.

Valve Guides

NOTE: Intake and exhaust guides are different.

1. Check valve stem-to-valve guide oil clearance. Ensure valve guide inside diameter is within specification. See **CYLINDER HEAD** table under ENGINE SPECIFICATIONS.
2. Completely disassemble cylinder head. Gradually heat cylinder head in water to 195°F (90°C). Using Valve Guide Remover (49-B012-005), drive valve guide out, working from combustion chamber side of cylinder head. Repeat procedure, if required, keeping cylinder head hot so aluminum head will not warp.
3. If required, install new circlip on guide. Using proper components of Valve Guide Installer (49-L012-0A0), install guide. Adjust installer guide depth (dimension "L") to specification using depth micrometer or caliper. See **VALVE GUIDE INSTALLED HEIGHT** table. See **Fig. 31**.
4. Insert guide into pre-adjusted installer, and drive guide into cylinder head from

1999 Mazda MX-5 Miata

1999-2000 ENGINES 1.8L 4-Cylinder

camshaft side until guide circlip and/or installer contact cylinder head. Measure dimension "L" (guide installed height). See **Fig. 31** or **Fig. 32** . If installed height is not within specification, adjust or replace valve guide or cylinder head as necessary. See **VALVE GUIDE INSTALLED HEIGHT** table.

VALVE GUIDE INSTALLED HEIGHT

Application	In. (mm)
Miata & Protege	.720-.744 (18.30-18.90)

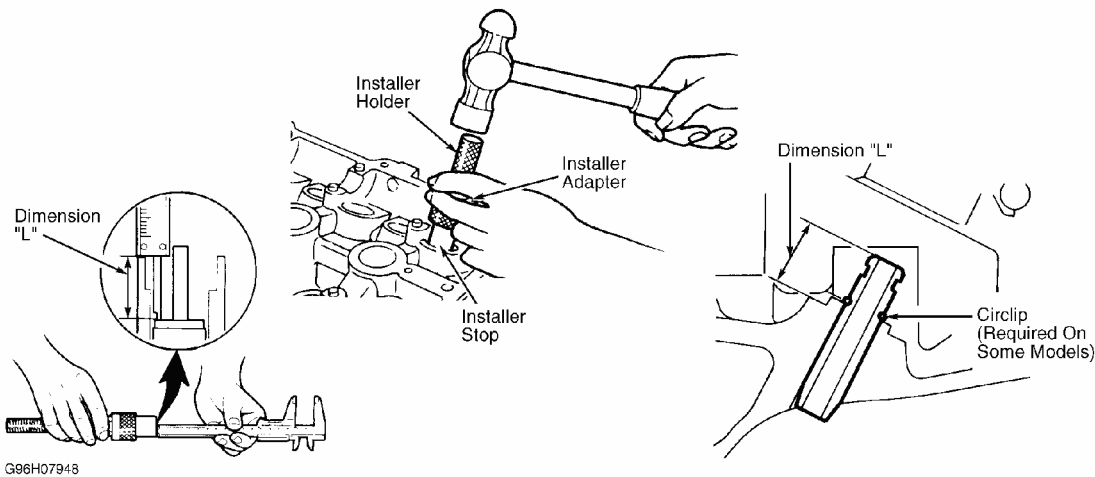

Fig. 31: Adjusting Valve Guide Installer & Installing Guide
Courtesy of MAZDA MOTORS CORP.

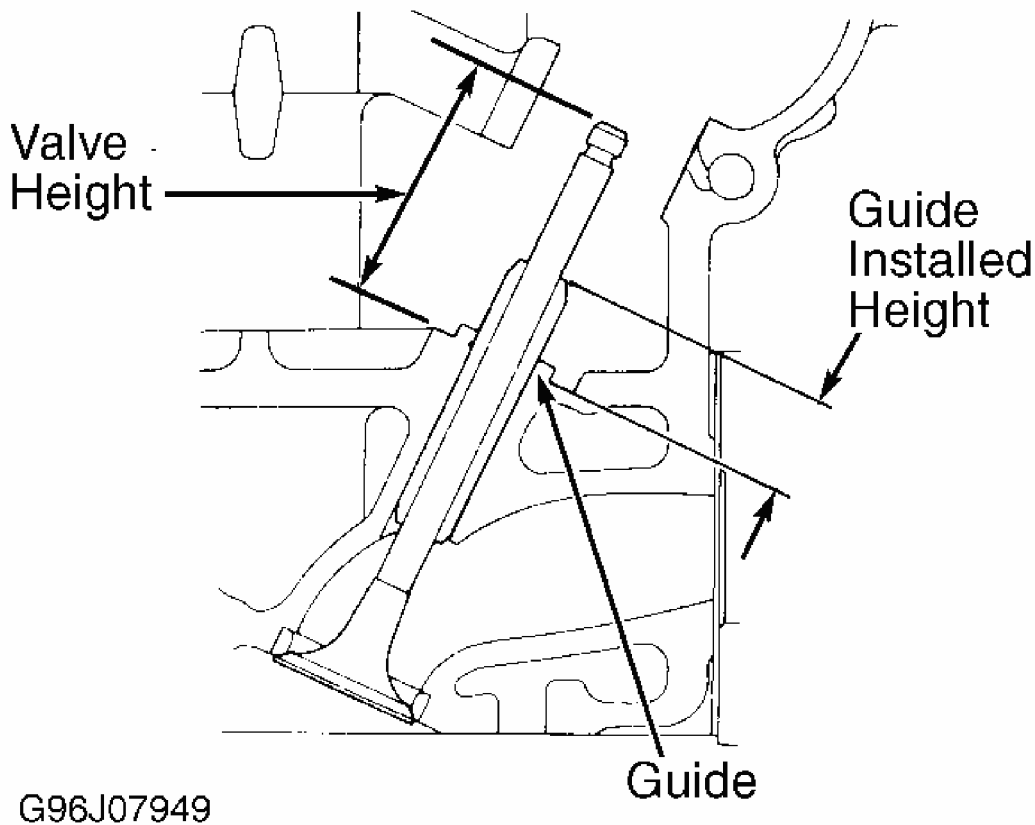

Fig. 32: Measuring Installed Valve & Guide Height
 Courtesy of MAZDA MOTORS CORP.

Valve Seat

1. Service valve guide before valve seat. Valve seat replacement information is not available from manufacturer. Inspect valve seat for roughness and damage. Check valve seat angle and seat width.
2. Measure seat contact width on valve, and ensure seat contact position is in center of valve face. Service seat if angle and width are not within specification. See **CYLINDER HEAD** table under ENGINE SPECIFICATIONS. Measure valve installed height after servicing valve seat. See **Fig. 32**. See **VALVE INSTALLED HEIGHT** table.
3. If valve installed height is within serviceable range, install adjusting shim on spring seat. If installed height exceeds serviceable range, replace cylinder head.

VALVE INSTALLED HEIGHT

Application	In. (mm)

1999 Mazda MX-5 Miata

1999-2000 ENGINES 1.8L 4-Cylinder

Miata & Protege

Normal	1.772-1.791 (45.00-45.50)
Serviceable	1.795-1.831 (45.60-46.50)

Valves

Check valve face angle, head diameter, margin thickness and stem diameter. Service or replace valves if measurements are not within specifications. See **VALVES & VALVE SPRINGS** table under ENGINE SPECIFICATIONS.

Valve Seat Correction Angles

Using a valve lapping compound, measure seat contact width on valve. See **VALVE SEAT**. If seat width is not within specification or if valve face does not contact center of valve seat, correct seat. If valve seat is too high, use a 70-degree grinding stone to lower seat. If valve seat is too low, use a 45-degree grinding stone to raise seat. After correcting seat, lightly finish seat with 45-degree grinding stone.

CYLINDER BLOCK ASSEMBLY

NOTE: During disassembly, match mark components for reassembly reference.

Piston & Connecting Rod Assembly

1. Before removing rod cap from crankshaft, measure and record rod side play. See **CONNECTING RODS** table under ENGINE SPECIFICATIONS. Before removing connecting rods, remove rod cap. Using plastigage, measure and record connecting rod bearing oil clearance. See **CRANKSHAFT, MAIN & CONNECTING ROD BEARINGS** table under ENGINE SPECIFICATIONS. Remove piston and rod assemblies.
2. Before separating piston from connecting rod, mark piston in relation to connecting rod. Check oscillation movement of piston and rod assembly (hold piston horizontally, lift rod and allow rod to drop by its own weight). If pin binds in pin bore (rod does not drop), replace piston and/or pin as necessary.
3. Using a piston ring expander, remove rings. Remove piston pin circlips from piston. Separate piston and rod by tapping on pin using a hammer and Piston Pin Remover/Installer (49-0221-061A).
4. Ensure piston pin oil clearance is within specification. See **PISTONS, PINS & RINGS** table under ENGINE SPECIFICATIONS. Install one piston pin circlip into piston on side without the "F" mark. Apply oil to piston pin and pin bore in piston and connecting rod. Insert pin into piston on side with the "F" mark. Using piston pin remover/installer,

tap pin into piston and connecting rod. Ensure oil groove in rod and "F" mark on piston are facing the same side. See **Fig. 33**. Install second piston pin circlip.

5. Using a piston ring expander, install piston rings. See **PISTON RINGS**. Coat cylinder walls and piston rings with oil. Using a ring compressor, install piston and rod assembly into cylinder block, with "F" mark on piston and oil groove on connecting rod, facing front of engine.

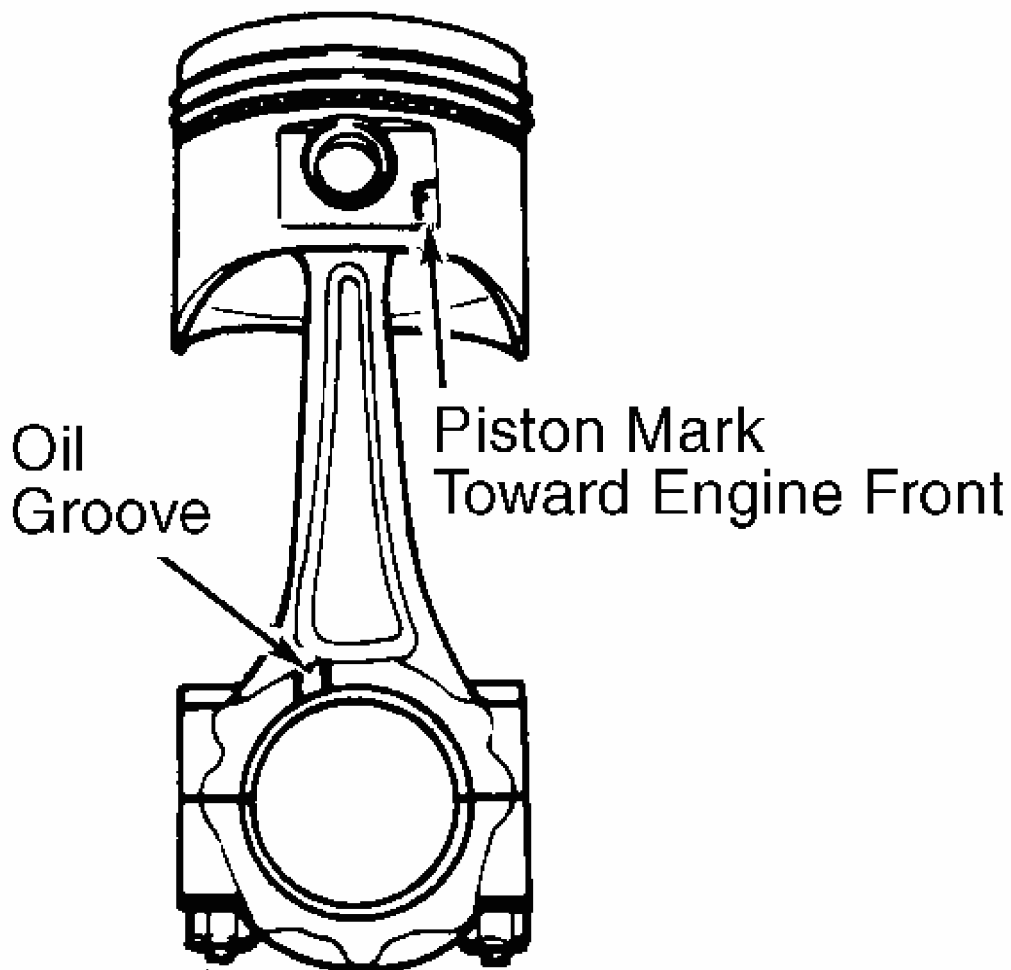

G96B07950

Fig. 33: Installing Piston & Connecting Rod Assembly
Courtesy of MAZDA MOTORS CORP.

1999 Mazda MX-5 Miata

1999-2000 ENGINES 1.8L 4-Cylinder

1. Ensure pistons are not scored or damaged. Measure piston diameter on piston skirt at 90-degree angle from piston pin, .65" (16.5 mm) below lowest ring groove. See **PISTONS, PINS & RINGS** table under ENGINE SPECIFICATIONS.
2. Check piston-to-cylinder wall clearance in 3 different vertical places of piston travel. If clearance is not within specification, re-bore cylinders to fit oversize pistons. Using NEW piston rings, measure piston ring side clearance around entire piston circumference. If clearance is not within specification, replace piston. See **PISTONS, PINS & RINGS** table under ENGINE SPECIFICATIONS.

NOTE: **Pistons and rings are available in .010" (.25 mm) and .020" (.50 mm) oversize.**

Piston Rings

1. If ring end gap and side clearance are not within specification, replace piston and/or rings as necessary. See **PISTONS, PINS & RINGS** table under ENGINE SPECIFICATIONS.
2. Install oil ring spacer. Ensure ends DO NOT overlap. See **Fig. 34**. Upper and lower rails are the same and are interchangeable. Install rails, ensuring rails are expanded by spacer tangs (oil rings, when assembled, should rotate freely). Using a piston ring expander, install rings No. 2 (second), with the mark facing top of piston or with the scraper facing down, and rings No. 1 (top), with the mark facing top of piston or with bevel/chamfer facing up. Ensure ring end gaps are properly positioned around piston. See **Fig. 35**.

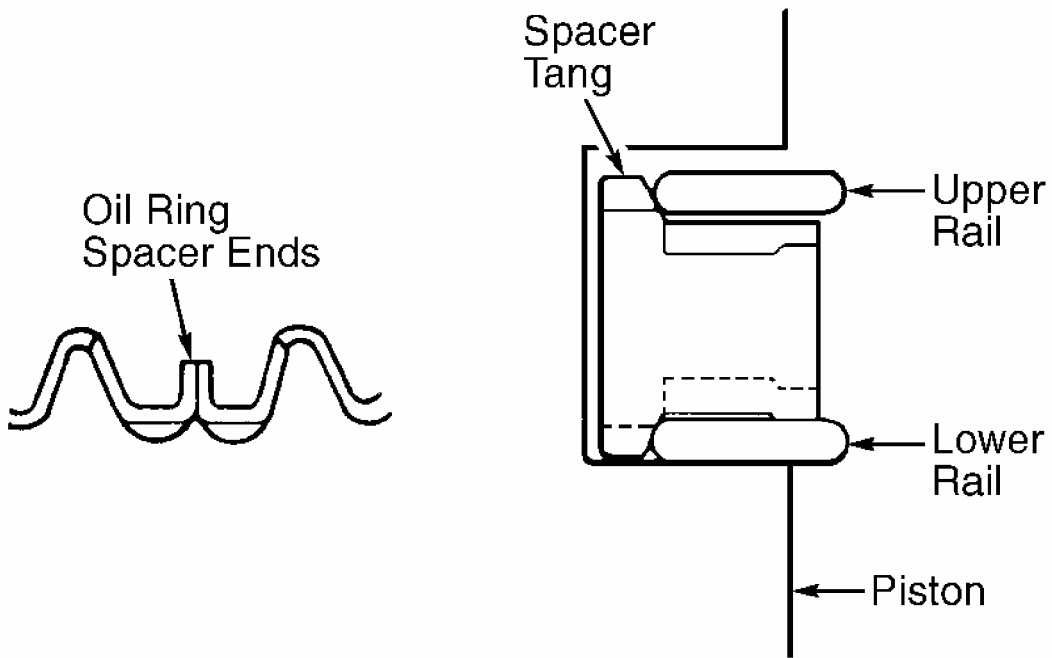

G93E84511

Fig. 34: Identifying Oil Rings
Courtesy of MAZDA MOTORS CORP.

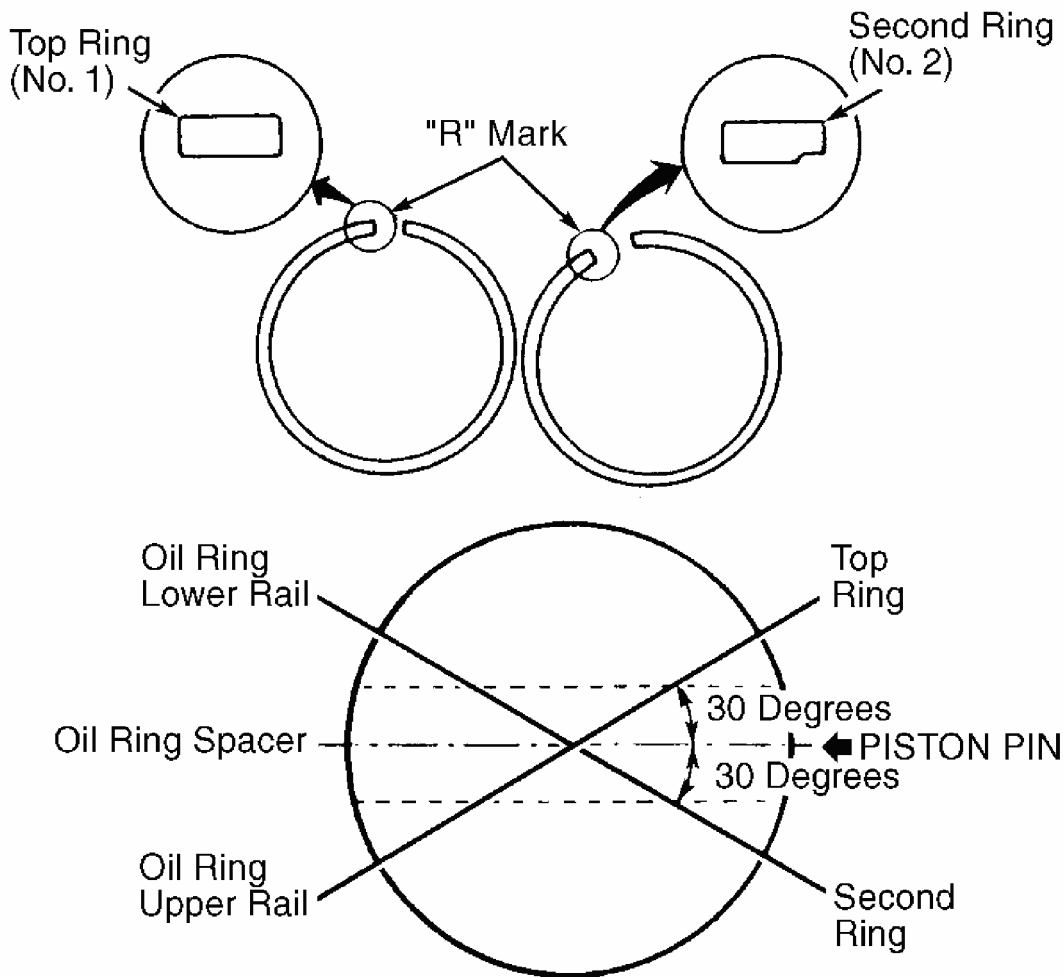

G93F84512

Fig. 35: Positioning Piston Ring End Gaps
 Courtesy of MAZDA MOTORS CORP.

Crankshaft & Main Bearings

1. Check crankshaft connecting rod journals for wear, out-of-round, taper and undersize. Machine or replace crankshaft and/or bearings as necessary. See **CRANKSHAFT, MAIN & CONNECTING ROD BEARINGS** table under ENGINE SPECIFICATIONS.
2. Before removing main cap, measure and record crankshaft end play by prying crankshaft forward, then rearward. Using Plastigage method, measure and record main bearing oil clearance. Remove main bearing caps in sequence. See [Fig. 36](#). Remove crankshaft. Measure and record each main journal diameter in 2 places. See **CRANKSHAFT, MAIN & CONNECTING ROD BEARINGS** table under ENGINE SPECIFICATIONS.
3. Install main bearing caps with mark facing front of engine. Tighten main bearing cap

bolts to specification, in 2-3 steps and in sequence. See **Fig. 37**. See **TORQUE SPECIFICATIONS**.

Thrust Bearing

Install main bearings, and coat with oil. Install crankshaft. Install main bearing caps, and torque to specification in 2-3 steps, and in sequence. See **Fig. 37**. Check end play with crankshaft bearings and caps installed. If crankshaft end play exceeds specification, grind crankshaft and replace thrust bearings with oversize thrust bearings, or replace crankshaft and thrust bearings. See **CRANKSHAFT, MAIN & CONNECTING ROD BEARINGS** table under ENGINE SPECIFICATIONS.

Cylinder Block

Check cylinder bore out-of-round, taper, ridge and piston-to-cylinder bore clearance. Check head gasket surface for warpage. If warpage is not within specification, machine or replace cylinder block as necessary. See **CYLINDER BLOCK** table under ENGINE SPECIFICATIONS. Remove, clean and install oil jets for piston oil spraying.

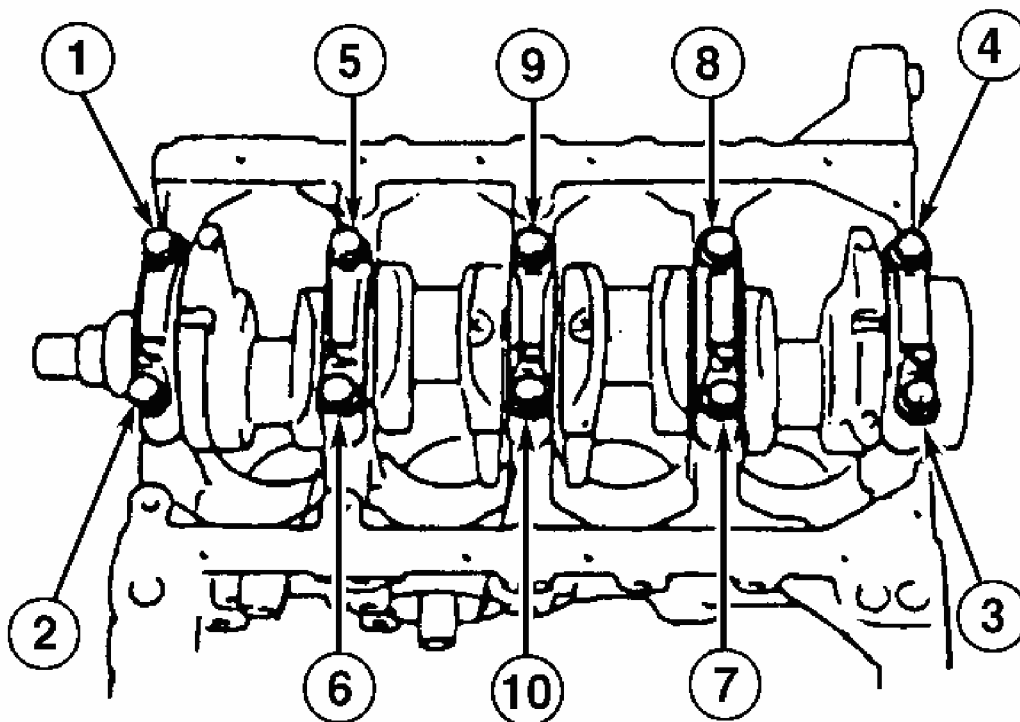

G00009918

Fig. 36: Main Bearing Cap Bolt Removal Sequence
Courtesy of MAZDA MOTOR CORP.

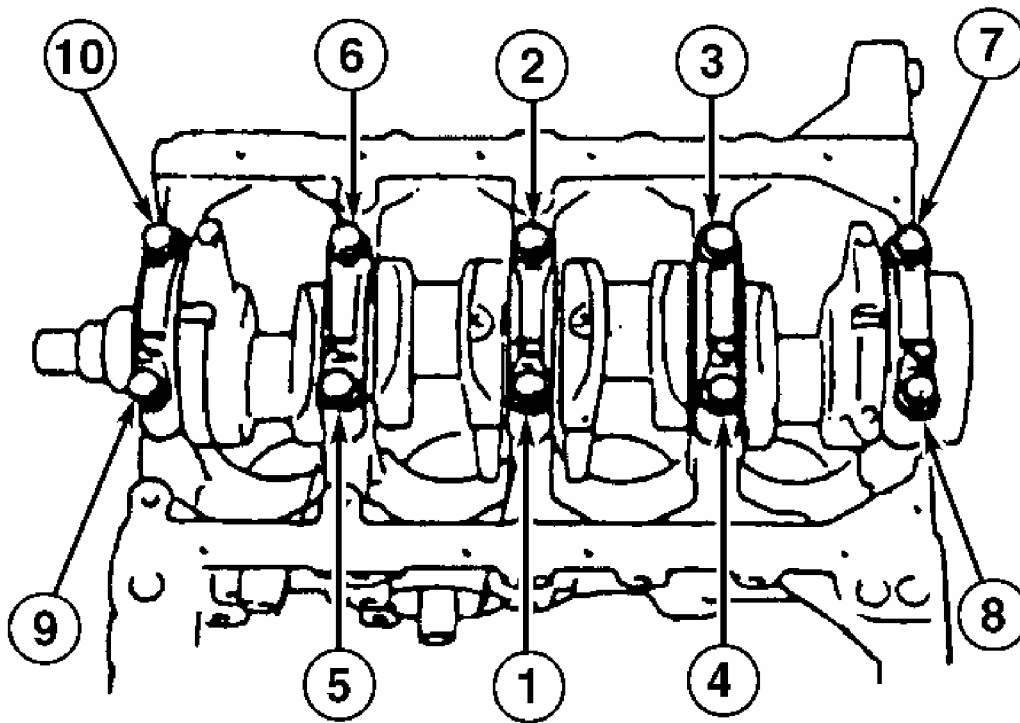

G00009919

Fig. 37: Main Bearing Cap Bolt Tightening Sequence
Courtesy of MAZDA MOTOR CORP.

ENGINE OILING

ENGINE LUBRICATION SYSTEM

NOTE: See cross-sectional view of engine oil circuit. See Fig. 38.

1999 Mazda MX-5 Miata

1999-2000 ENGINES 1.8L 4-Cylinder

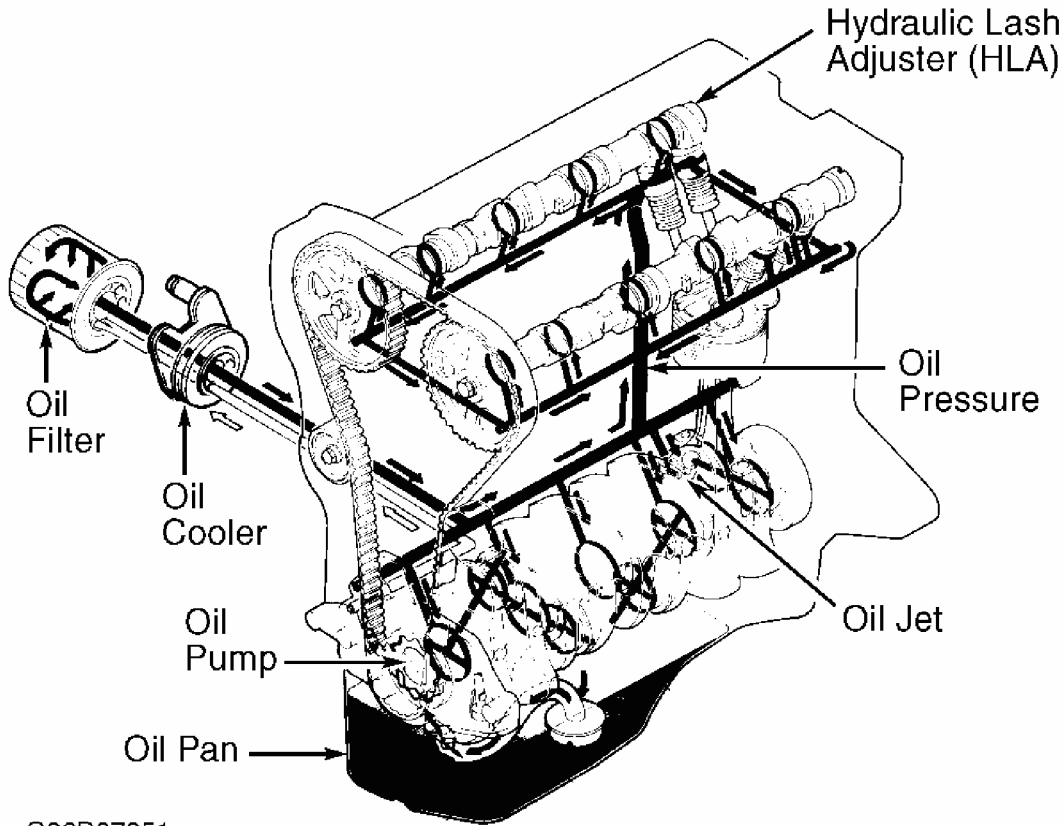

G96D07951

Fig. 38: Cross-Sectional View Of Engine Oil Circuit
Courtesy of MAZDA MOTORS CORP.

Crankcase Capacity

See **ENGINE OIL CRANKCASE CAPACITY** table.

Oil Pressure

With engine at normal operating temperature, oil pressure should be 15-28 psi (1.0-2.0 kg/cm²) at 1000 RPM, and 43-57 psi (3.0-4.0 kg/cm²) at 3000 RPM.

Oil Pressure Relief Valve

Pressure relief valve opening pressure is 50-64 psi (3.5-4.5 kg/cm²). Pressure relief valve is located in oil pump body and is not adjustable.

ENGINE OIL CRANKCASE CAPACITY

Application	W/O Filter - Qts. (L)	W/ Filter - Qts. (L)
Miata	3.8 (3.6)	4.0 (3.8)

1999 Mazda MX-5 Miata

1999-2000 ENGINES 1.8L 4-Cylinder

Protege

3.5 (3.3)

3.7 (3.5)

OIL PUMP

Removal & Disassembly

1. Disconnect negative battery cable. Remove dipstick, tube and "O" ring. Drain engine oil and coolant. Remove drive belts, crankshaft and water pump pulleys. Remove generator. Remove A/C compressor and mounting bracket with hoses attached, and suspend aside. Remove timing belt and related components. See **TIMING BELT** under REMOVAL & INSTALLATION.
2. Hold crankshaft in place, and remove crankshaft sprocket lock bolt. Remove crankshaft sprocket boss and sprocket. Leave crankshaft Woodruff key in place.
3. Remove oil pan and oil pump pick-up tube. See **OIL PAN** under REMOVAL & INSTALLATION. Remove oil pump housing assembly. Using a screwdriver, protected with a rag, drive oil seal out from inside of oil pump housing assembly.
4. Remove pump cover screws (use a manual impact screwdriver, if necessary). Remove pump cover. Note location of alignment marks on inner and outer rotors. Remove inner and outer rotors. To remove pressure relief valve, remove cotter pin, spring seat, pressure spring and control plunger. See **Fig. 39**.

Inspection

Replace pressure relief valve spring if length is not as specified. See **OIL PUMP SPECIFICATIONS** table. Ensure plunger slides freely in bore. Replace oil pump housing assembly if clearances are not as specified. See **OIL PUMP SPECIFICATIONS** table.

Reassembly & Installation

1. Apply oil to friction surfaces. Install inner and outer rotors with marks aligned. See **Fig. 40**. Install pressure relief valve components. Apply oil to lip of NEW oil seal. Press oil seal into place until flush with face of oil pump housing assembly.
2. Install pump cover. Tighten screws to 53-80 INCH lbs. (6-9 N.m). To complete installation, reverse removal procedure. Tighten bolts to specification. See **TORQUE SPECIFICATIONS**.

OIL PUMP SPECIFICATIONS

Application	Maximum Clearance - In. (mm)
Maximum Rotor Side Clearance ⁽¹⁾	.0055 (.14)
Maximum Rotor Tip Clearance ⁽²⁾	.0079 (.20)
Maximum Rotor-To-Pump Body Clearance ⁽³⁾	.0087 (.22)
	1.394 (35.42)

Pressure Relief Spring Length ⁽⁴⁾

- (1) Insert feeler gauge between outer rotor and pump body.
- (2) Place straightedge across pump body, and check clearance between straightedge and both rotors.
- (3) See **Fig. 40**.
- (4) Using 14.1-15.4 lbs. (6.4-7.0 kg) of force.

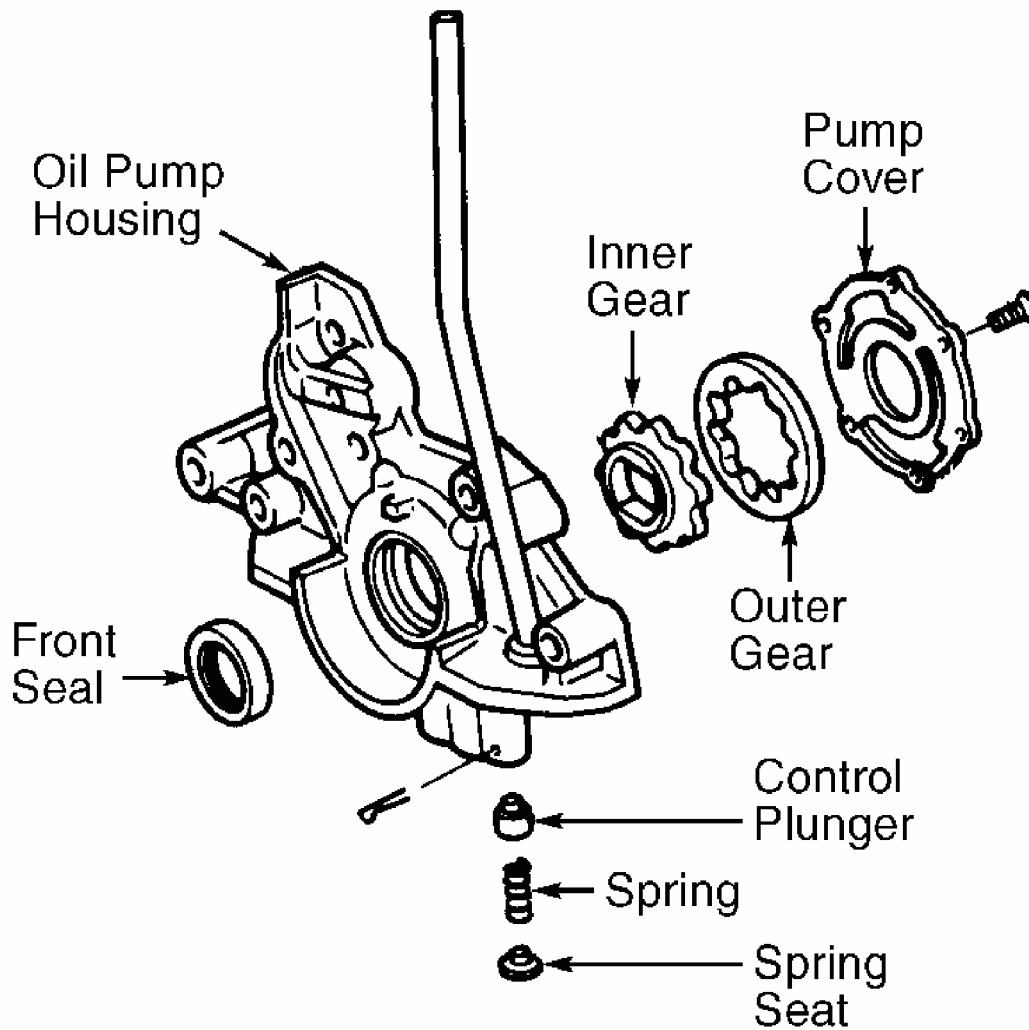

G96F07952

Fig. 39: Exploded View Of Oil Pump
Courtesy of MAZDA MOTORS CORP.

1999 Mazda MX-5 Miata

1999-2000 ENGINES 1.8L 4-Cylinder

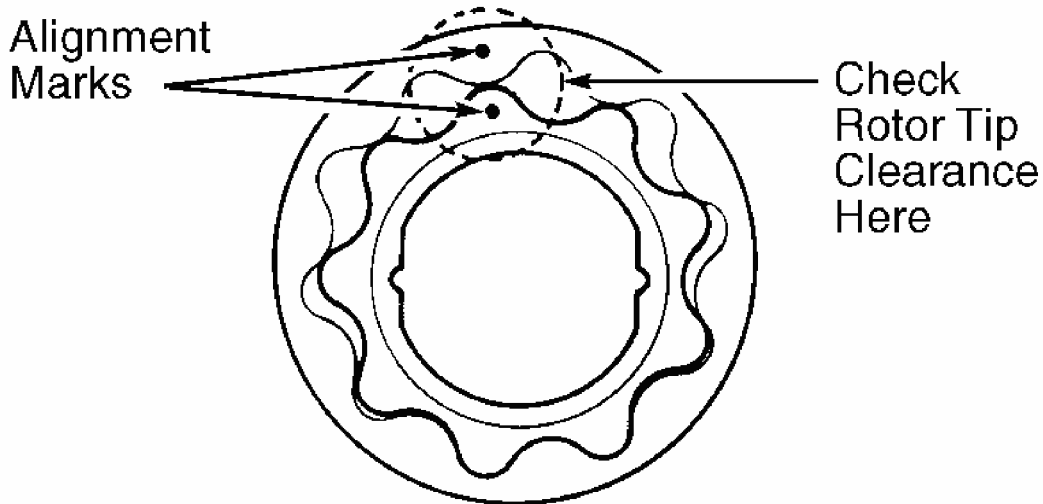

G93I84515

Fig. 40: Aligning Marks On Inner & Outer Rotor
Courtesy of MAZDA MOTORS CORP.

TORQUE SPECIFICATIONS

TORQUE SPECIFICATIONS

Application	Ft. Lbs. (N.m)
Axle Shaft Nut (Protege)	173-235 (235-319)
Camshaft Sprocket Bolt	37-44 (50-60)
Compressor Bracket-To-Engine Bolts	28-38 (38-51)
Connecting Rod Cap Nuts	35-37 (48-50)
Crankshaft Pulley Bolts	9-13 (12-18)
Crankshaft Sprocket Lock Bolt	116-123 (157-167)
Crossmember-To-Frame Bolts	46-66 (63-89)
Cylinder Head Bolts	⁽¹⁾ 56-60 (76-81)
Drive Shaft Bolts (Miata)	37-43 (50-58)
Engine Mount-To-Engine Bolts	28-38 (38-51)
Engine Mount-To-Frame Nuts	
Miata	42-57 (57-77)
Protege	49-69 (67-93)
Exhaust Flange-To-WU/TWC Nuts	28-38 (38-51)
Exhaust Manifold Nuts/Bolts ⁽²⁾	
Miata	29-34 (39-46)

1999 Mazda MX-5 Miata

1999-2000 ENGINES 1.8L 4-Cylinder

Protege	14-21 (19-28)
Flywheel Bolts	71-76 (96-103)
Fuel Rail Bolts	14-19 (19-26)
Generator Top Bolt	14-18 (19-24)
Intake Manifold Nuts/Bolts	(2) 14-19 (19-26)
Intake Manifold Support Bracket	28-38 (38-51)
Main Bearing Cap Bolts	
Step 1	(2) 22-27 (30-37)
Step 2 (Final)	(2) 40-43 (54-58)
Oil Jet	9-13 (12-18)
Oil Pump-To-Block Bolts	14-19 (19-26)
Power Steering Pump-To-Bracket Bolts	28-38 (38-51)
PPF-To-Differential Long Mounting Bolts	77-91 (104-123)
PPF-To-Differential Spacer Mounting Bolts	27-38 (37-51)
PPF-To-Transmission Rear Bracket Mounting Bolt	27-40 (37-54)
Spark Plugs	11-16 (15-22)
Timing Belt Tensioner Bolt	27-38 (37-51)
Water Pump Bolts	14-19 (19-26)
	INCH Lbs. (N.m)
Camshaft Bearing Cap Bolts	(3) 100-125 (11.3-14.1)
Oil Pan-To-Engine Bolts	71-97 (8-11)
Oil Pump Cover Screws	53-80 (6-9)
Oil Strainer Bolts	71-97 (8-11)
Rear Cover Bolts	71-97 (8-11)
Timing Belt Cover Bolts	71-97 (8-11)
Valve Cover Bolts	
Miata	44-78 (5.0-8.8)
Protege	61-87 (6.9-9.8)
Water Pump Pulley Bolts	71-97 (8-11)

(1) Tighten in sequence. See **Fig. 19**.

(2) Tighten evenly to specification in alternating sequence.

(3) Tighten in sequence. See **Fig. 21** or **Fig. 22** .

ENGINE SPECIFICATIONS**GENERAL SPECIFICATIONS**

1999 Mazda MX-5 Miata

1999-2000 ENGINES 1.8L 4-Cylinder

Application	Specification
Displacement	112.2 Cu. In. (1.8L)
Bore	3.27" (83.0 mm)
Stroke	3.35" (85.0 mm)
Compression Ratio	
Miata	9.5:1
Protege	9.0:1
Fuel System	PFI

CRANKSHAFT, MAIN & CONNECTING ROD BEARINGS

Application	In. (mm)
Crankshaft	
End Play	
Standard	.0032-.0111 (.080-.282)
Maximum	.012 (.30)
Maximum Runout	.0012 (.03)
Main Bearings	
Journal Diameter	
Standard Bearings	1.9661-1.9667 (49.938-49.956)
Journal Out-Of-Round	.002 (.05)
Oil Clearance	
Standard	.0007-.0014 (.018-.036)
Maximum	.004 (.10)
Connecting Rod Bearings	
Journal Diameter	
Standard Bearings	1.7693-1.7699 (44.940-44.956)
Journal Out-Of-Round	.002 (.05)
Oil Clearance	
Standard	.0011-.0018 (.028-.048)
Maximum	.0039 (.100)

CONNECTING RODS

Application	In. (mm)
Bore Diameter	
Crankpin Bore	1.8898-1.8904 (48.000-48.016)
Pin Bore	.7875-.7879 (20.003-

1999 Mazda MX-5 Miata

1999-2000 ENGINES 1.8L 4-Cylinder

	20.014)
Center-To-Center Length	5.087 (129.2)
Maximum Bend	(1)
Side Play	
Standard	.0043-.0103 (.110-.262)
Maximum	.012 (.30)
(1) Bend must not exceed .002" (.05 mm) per 1.97" (50 mm) of rod length.	

PISTONS, PINS & RINGS

Application	In. (mm)
Pistons	
Clearance	
Standard	
Miata	.0013-.0023 (.032-.059)
Protege	.0010-.0026 (.025-.066)
Maximum	.006 (.15)
Diameter	
Standard	3.2659-3.2667 (82.953-82.975)
Oversize	
.010" (0.25 mm)	3.2757-3.2766 (83.203-83.225)
.020" (0.50 mm)	3.2855-3.2864 (83.453-83.475)
Pins	
Diameter	.7869-.7871 (19.987-19.993)
Piston Fit	-.0002-.0005 (-.005-.013)
Rings	
No. 1 (Top)	
End Gap	
Standard	.006-.012 (.15-.30)
Maximum	.039 (1.0)
Side Clearance	
Standard	.0012-.0025 (.030-.065)
Maximum	.006 (.15)
No. 2 (Scraper)	
End Gap	
Standard	.012-.017 (.30-.45)

1999 Mazda MX-5 Miata

1999-2000 ENGINES 1.8L 4-Cylinder

Maximum	.039 (1.0)
Side Clearance	
Standard	.0012-.0027 (.030-.070)
Maximum	.006 (.15)
No. 3 (Oil)	
End Gap	
Standard	.008-.027 (.20-.70)
Maximum	.039 (1.0)

CYLINDER BLOCK

Application	In. (mm)
Cylinder Bore	
Standard	3.2678-3.2684 (83.000-83.019)
Oversize	
.010" (0.25 mm)	3.2776-3.2783 (83.250-83.269)
.020" (0.50 mm)	3.2874-3.2881 (83.500-83.519)
Maximum Taper & Out-Of-Round	.006 (.15)
Minimum Deck Height ⁽¹⁾	8.720 (221.5)
Maximum Deck Warp	.006 (.15)
(1) DO NOT machine more than .008" (.20 mm) from cylinder block deck surface.	

CYLINDER HEAD

Application	Specification
Cylinder Head	
Bolt Length	
Standard	4.102-4.126" (104.2-104.8 mm)
Maximum	4.154" (105.5 mm)
Height	5.268-5.275" (133.8-134.0 mm)
Surfacing Limit	.004" (.10 mm)
Maximum Warp	.004" (.10 mm)
Valve Seats	
Intake Valve	
Seat Angle	45 Degrees
Seat Width	.031-.055" (0.80-1.40 mm)

1999 Mazda MX-5 Miata

1999-2000 ENGINES 1.8L 4-Cylinder

Exhaust Valve	
Seat Angle	45 Degrees
Seat Width	.031-.055" (0.80-1.40 mm)
Valve Guides	
Intake Valve	
Valve Guide I.D.	.2370-.2378" (6.02-6.04 mm)
Valve Guide Installed Height	.720-.744" (18.3-18.9 mm)
Valve Stem-To-Guide Oil Clearance	
Standard	.0010-.0023" (.025-.060 mm)
Maximum	.008" (.20 mm)
Exhaust Valve	
Valve Guide I.D.	.2370-.2378" (6.02-6.04 mm)
Valve Guide Installed Height	.720-.744" (18.3-18.9 mm)
Valve Stem-To-Guide Oil Clearance	
Standard	.0012-.0025" (.030-.065 mm)
Maximum	.008" (.20 mm)

VALVES & VALVE SPRINGS

Application	Specification
Valves	
Face Angle	45 Degrees
Installed Height	
Normal	1.772-1.791" (45.00-45.50 mm)
Serviceable	1.795-1.831" (45.60-46.50 mm)
Minimum Head Margin	
Intake	.035" (0.9 mm)
Exhaust	.039" (1.0 mm)
Refinish Length	
Miata	
Intake	
Standard	4.016" (102.01 mm)
Minimum	3.952" (100.39 mm)
Exhaust	
Standard	4.016" (102.01 mm)
Minimum	3.956" (100.49 mm)
Protege	
Intake	

1999 Mazda MX-5 Miata

1999-2000 ENGINES 1.8L 4-Cylinder

Standard	4.0043-4.0279" (101.71-102.31 mm)
Minimum	4.0004" (101.61 mm)
Exhaust	
Standard	4.0043-4.0279" (101.71-102.31 mm)
Minimum	4.0004" (101.61 mm)
Stem Diameter	
Intake	
Standard	.2350-.2356" (5.970-5.985 mm)
Minimum	.2330" (5.920 mm)
Exhaust	
Standard	.2348-.2354" (5.965-5.980 mm)
Minimum	.2329" (5.915 mm)
Valve Springs	
Free Length	1.821" (46.26 mm)
Maximum Out-Of-Square	.064" (1.63 mm)
Compressed Length ⁽¹⁾	
Minimum	1.55" (39.5 mm)
(1) Using 43.87 lbs. (19.9 kg) of pressure.	

CAMSHAFT

Application	In. (mm)
End Play	
Standard	.0028-.0074 (.07-.19)
Maximum	.008 (.20)
Journal Diameter	1.0212-1.0222 (25.940-25.965)
Maximum Journal Out-Of-Round	.0012 (.03)
Maximum Journal Runout	.0012 (.03)
Journal Oil Clearance	
Standard	.0014-.0032 (.035-.081)
Maximum	.006 (.15)
Lobe Height	
Standard	
Intake	1.744 (44.30)
Exhaust	1.768 (44.90)
Minimum	

1999 Mazda MX-5 Miata

1999-2000 ENGINES 1.8L 4-Cylinder

Intake	1.736 (44.10)
Exhaust	1.760 (44.70)

VALVE TAPPETS

Application	In. (mm)
Bore Diameter	1.1811-1.1821 (30.000-30.025)
Lifter Diameter	1.1795-1.1801 (29.959-29.975)
Oil Clearance	
Standard	.0010-.0026 (.025-.066)
Maximum	.0071 (.180)